



A WILO COMPANY

MOTORPUMP™ — 1750 RPM

Iron, 60 Hz, 6 X 5 X 7 ANSI FLG

59 JM



MOTOR DIMENSIONS

NEMA JM FRAME 3 PHASE 1750 RPM

HP	Type	Frame	D	E	F	O	AB	BG	L	MH
3	ODP	JM182	4.50	3.75	2.25	8.56	6.70	5.75	6.65	0.41
5	ODP	JM184	4.50	3.75	2.75	8.56	6.70	6.25	7.33	0.41
7.5	ODP	JM213	5.25	4.25	2.75	10.14	7.97	7.00	6.46	0.41
10	ODP	JM215	5.25	4.25	3.50	10.14	7.97	7.75	5.72	0.41
3	TEFC	JM182	4.50	3.75	2.25	8.85	7.57	5.01	7.14	0.41
5	TEFC	JM184	4.50	3.75	2.75	8.85	7.57	5.51	7.64	0.41
7.5	TEFC	JM213	5.25	4.25	2.75	10.41	8.67	6.00	8.41	0.41
10	TEFC	JM215	5.25	4.25	3.50	10.37	8.19	6.77	9.16	0.41

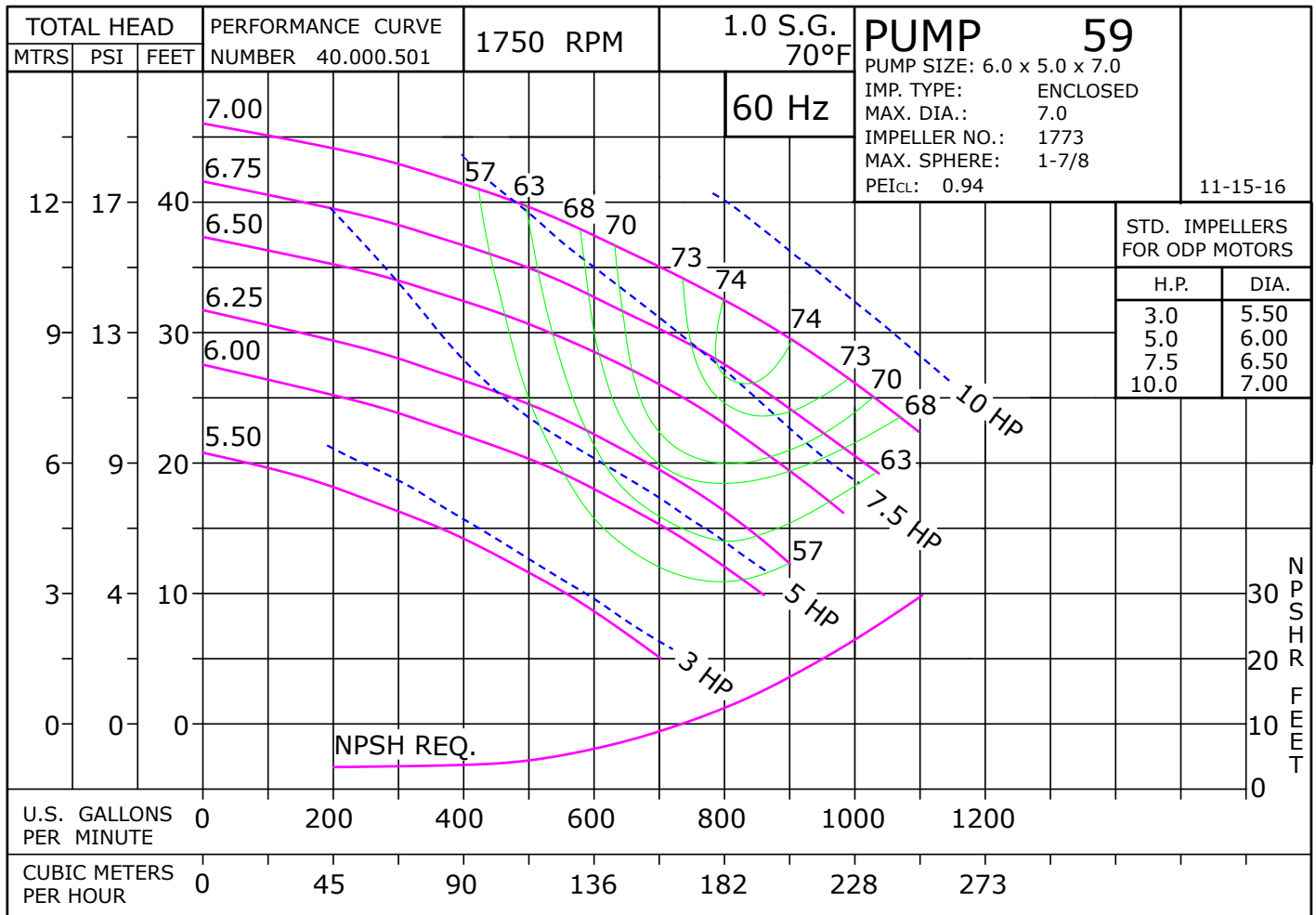
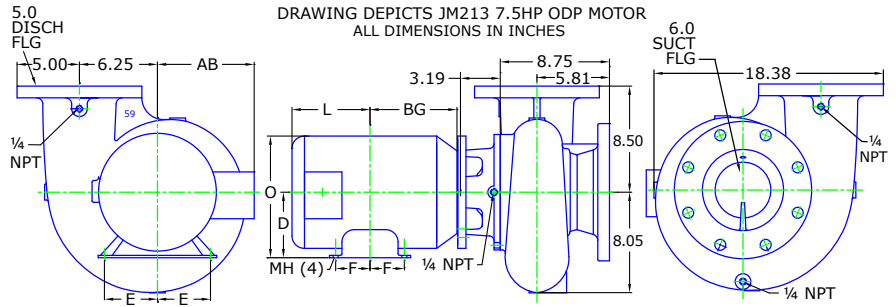

Parts

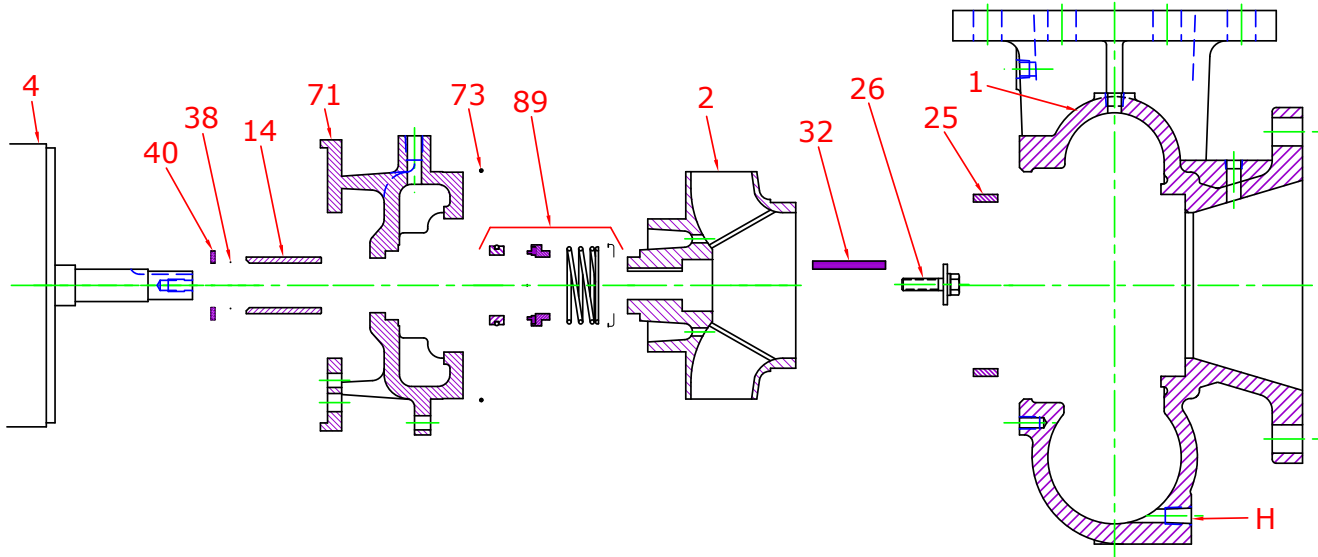

Key No.	Part Name	Part Number
1+	Case 59, Iron, 6.00 X 5.00 FLGI Bronze Wear Ring and plugs	137.000.563X
2	Impeller 59, Bronze, Specify Dia., 7.00" Max 7/8" Key	137.001.016
	Impeller 59, Iron, Specify Dia., 7.00" Max 7/8" Key	137.000.564
4	Motor chart, JM140/180	See Chart
	Motor chart, JM210	See Chart
14*	Shaft sleeve, Bronze	110.000.215
	Shaft Sleeve, Stainless	110.000.373
25	Wear Ring, Bronze	137.000.565
26*	Impeller retaining assembly, Stainless	118.000.609
32*	Key, Stainless	102.000.256
38*	O-ring, Shaft, Buna	116.000.117
	O-ring, Shaft, Viton	116.000.105
40*	Flinger, Stainless	104.000.256
71	Adapter, Iron, JM140/210 1-1/2" Seal, Brass plug	137.000.566X
73*	Gasket, Case, Buna	116.000.184
89*	Seal, 1-1/2", Type 21, BN-CARB/CM	101.000.168
	Seal, 1-1/2", Type 21, EPDM-CARB/SIL	101.000.175B
	Seal, 1-1/2", Type 21, EPDM-SIL/SIL	101.000.204A
	Seal, 1-1/2", Type 21, VN-CARB/CM	101.000.191
	Seal, 1-1/2", Type 21, VN-CARB/SIL	101.000.175
	Seal, 1-1/2", Type 21, VN-SIL/SIL	101.000.204
KIT	Repair Kit, 1-1/2" BN-CARB/CM Seal, Brz sleeve, BN O-ring	118.000.529
	Repair Kit, 1-1/2" EPDM-CARB/SIL Seal, Brz sleeve, BN O-ring	118.000.529D
	Repair Kit, 1-1/2" EPDM-SIL/SIL Seal, Brz sleeve, BN O-ring	118.000.529E
	Repair Kit, 1-1/2" VN-CARB/CM Seal, Stn sleeve, VN O-ring	118.000.529A
	Repair Kit, 1-1/2" VN-CARB/SIL Seal, Brz sleeve, BN O-ring	118.000.529B
	Repair Kit, 1-1/2" VN-SIL/SIL Seal, Stn sleeve, VN O-ring	118.000.529C

* Denotes components included in repair kit.

+ Includes bronze wear ring. For steel, replace suffix "X" with "X1".

Motor Charts

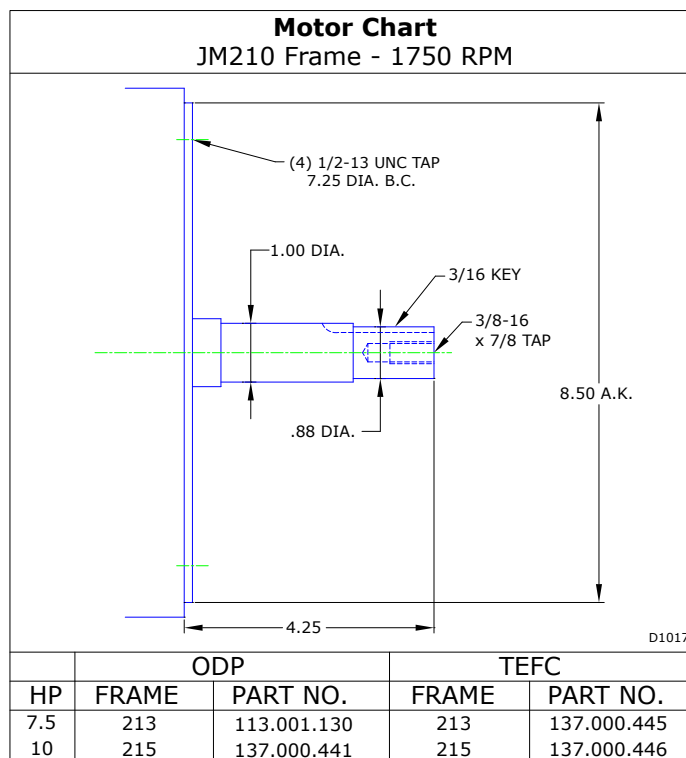
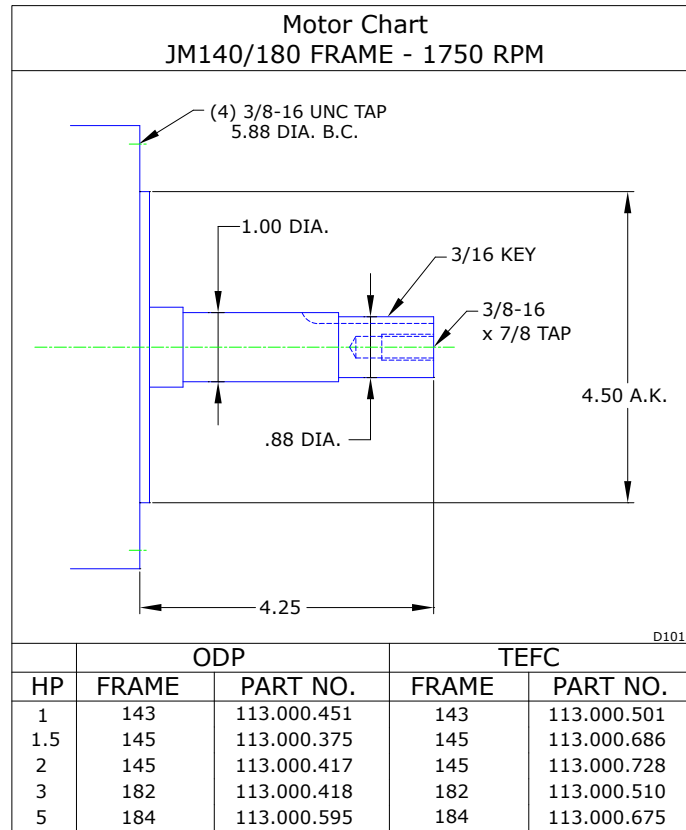

Construction Options

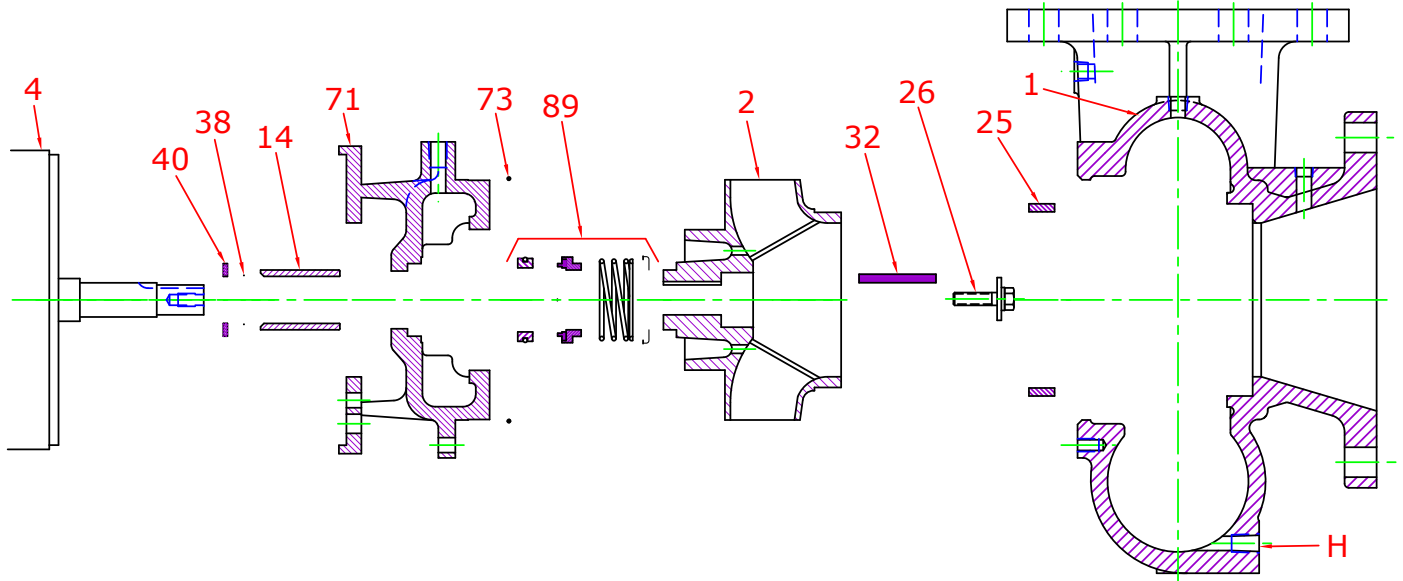

Construction Options				
Key	Part Name	Standard Fitted	Bronze Fitted	All Iron
1	Case	Iron	Iron	Iron
2	Impeller	Iron	Bronze	Iron
14	Shaft Sleeve	Bronze	Bronze	Stainless
25	Wear Ring	Bronze	Bronze	Steel
26	Impeller Retaining Assembly	Stainless	Stainless	Stainless
32	Key	Stainless	Stainless	Stainless
38	O-Ring, Shaft	Buna	Buna	Buna
40	Flinger	Stainless	Stainless	Stainless
71	Adapter	Iron	Iron	Iron
73	Gasket, Case	Buna	Buna	Buna
89	Mechanical Seal, Type 21 BN-CM	Standard	Standard	Standard
H	Plug, Drain	Brass	Brass	Plated Steel