

MOTOR DIMENSIONS NEMA JM FRAME 3 PHASE

HP	TYPE	FRAME	D	E	F	O	AB	BG	L	MH
1.0	ODP	JM143	3.50	2.75	2.00	6.75	4.50	4.88	6.31	.34
1.5	ODP	JM145	3.50	2.75	2.00	6.75	3.75	4.88	6.31	.34
1.0	TEFC	JM143	3.50	2.75	2.00	7.16	6.09	4.25	5.63	.34
1.5	TEFC	JM145	3.50	2.75	2.00	7.16	6.09	4.75	5.13	.34

D057JM145

DRAWING DEPICTS JM145 1HP ODP MOTOR

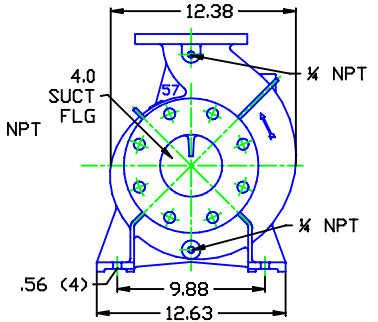
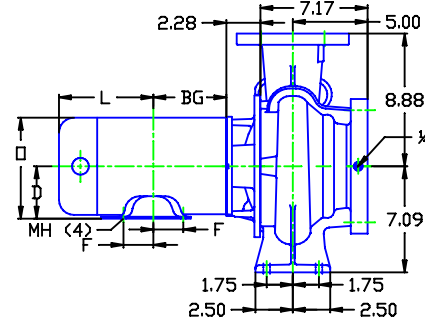
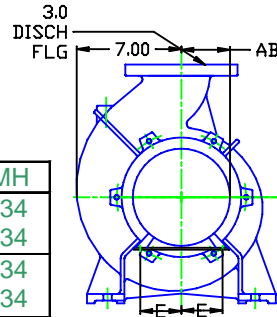

ALL DIMENSIONS IN INCHES.

DRAWING REPRESENTS APPROXIMATE PUMP DIMENSIONS. AUTOCAD DRAWING TO SCALE AVAILABLE FROM

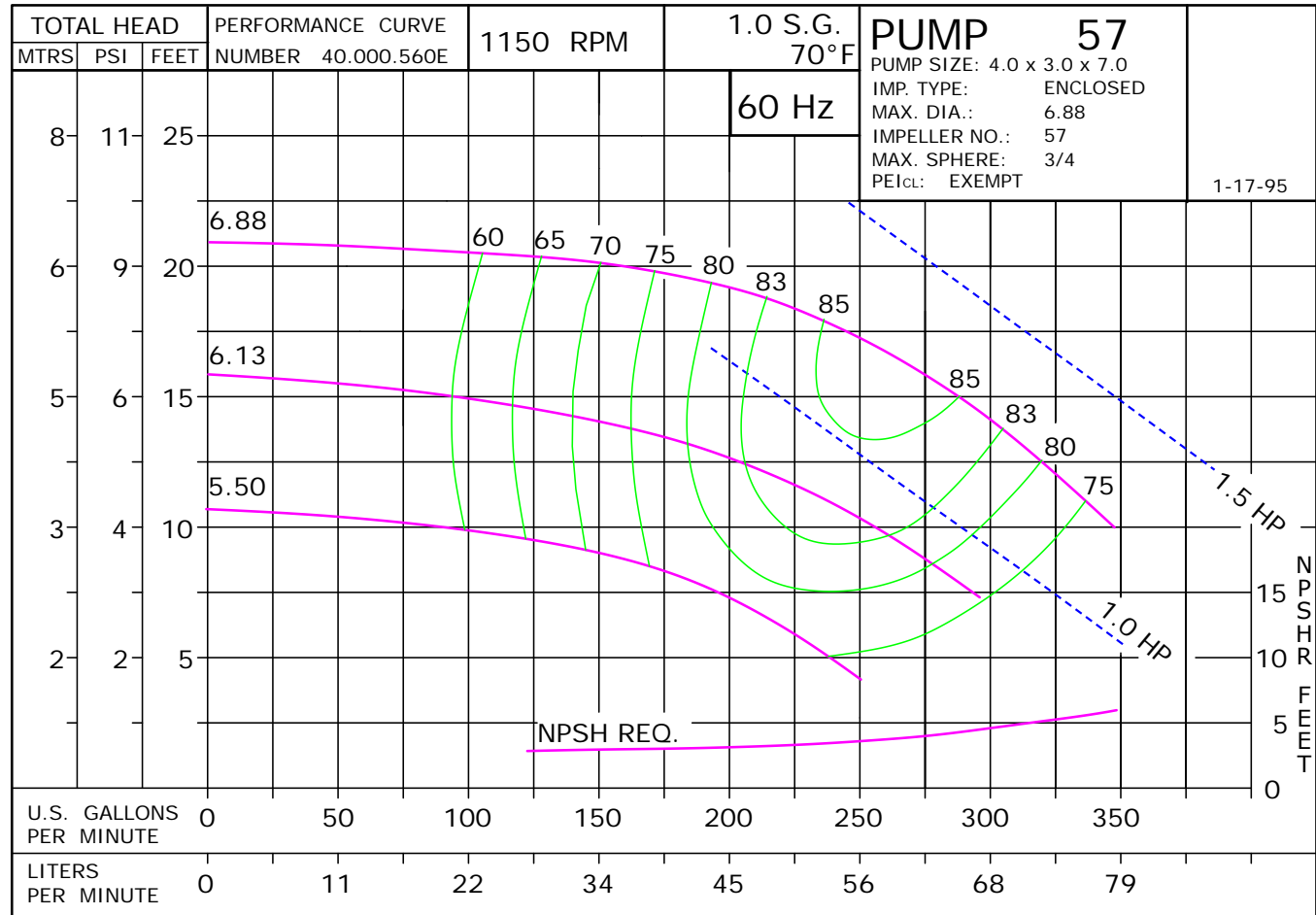

0575DP

D057JM145
0571150

57

JM

057M1150
81.001.810 M19

Pump 57 • Iron • JM Frame • 1150 RPM

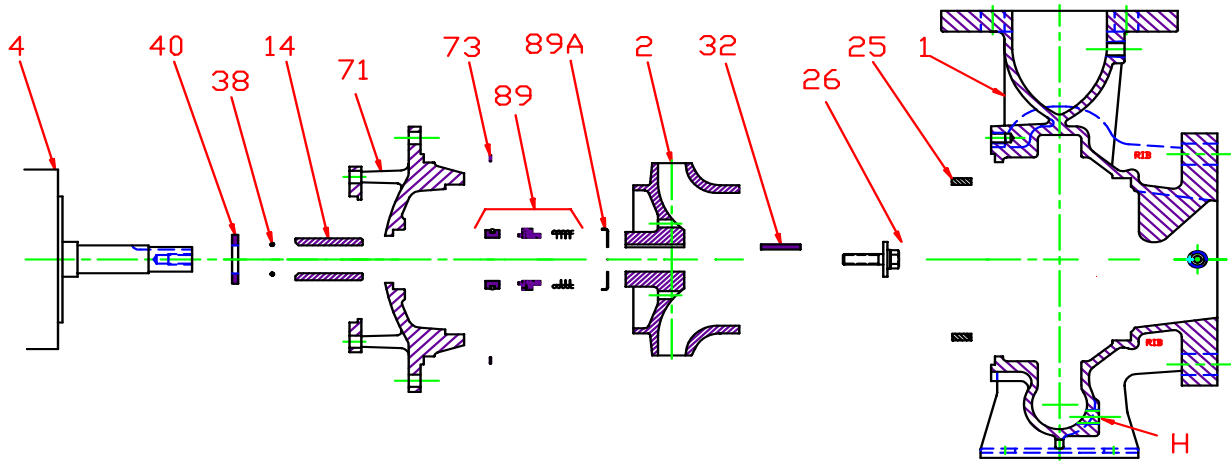

KEY NO.	PART NAME	PUMP NO. 57	
1+	CASE, IRON, 4 x 3 FLG	130.000.297X	
2	IMPELLER, 7/8" KEYED, ENCLOSED, SPECIFY DIAMETER: IRON BRONZE	137.000.122 137.000.222	
4	MOTOR, JM140/180	See Chart	
14*	SHAFT SLEEVE, BRONZE SHAFT SLEEVE, STAINLESS	110.000.215 110.000.373	
25	WEAR RING, BRONZE WEAR RING, STEEL	103.000.197 103.000.218	
26*	IMPELLER RETAINER, STAINLESS	118.000.163A	
32*	KEY, STAINLESS	102.000.256	
38*	O-RING, SHAFT, BUNA O-RING, SHAFT, VITON	116.000.117 116.000.105	
40*	FLINGER, STAINLESS	104.000.256	
71	ADAPTER, IRON - JM140/180	132.000.339X	
73*	GASKET, CASE, FIBER	116.000.273	
89*	1½" SEALS: BN-CARB/CM VN-CARB/CM VN-CARB/SIL VN-SIL/SIL EPDM-CARB/SIL EPDM-SIL/SIL	101.000.168 101.000.191 101.000.175 101.000.204 101.000.175B 101.000.204A	
	89A*	SEAL RETAINER, STAINLESS	104.000.174
	--	° REPAIR KITS: BN-CARB/CM SEAL VN-CARB/CM SEAL (S) VN-CARB/SIL SEAL VN-SIL/SIL SEAL (S) EPDM-CARB/SIL SEAL EPDM-SIL/SIL SEAL	118.000.383 118.000.383A 118.000.383B 118.000.383E 118.000.383C 118.000.383D

* DENOTES COMPONENTS INCLUDED IN REPAIR KIT.
 + INCLUDES BRONZE WEAR RING. FOR STEEL WEAR RING, REPLACE SUFFIX "X" WITH "X1".
 ° ALL REPAIR KITS INCLUDE THE BRONZE SHAFT SLEEVE EXCEPT THE (S) INDICATED, WHICH IS STAINLESS WITH VITON SHAFT O-RING.

Pump 57 • Iron • JM Frame • 1150 RPM

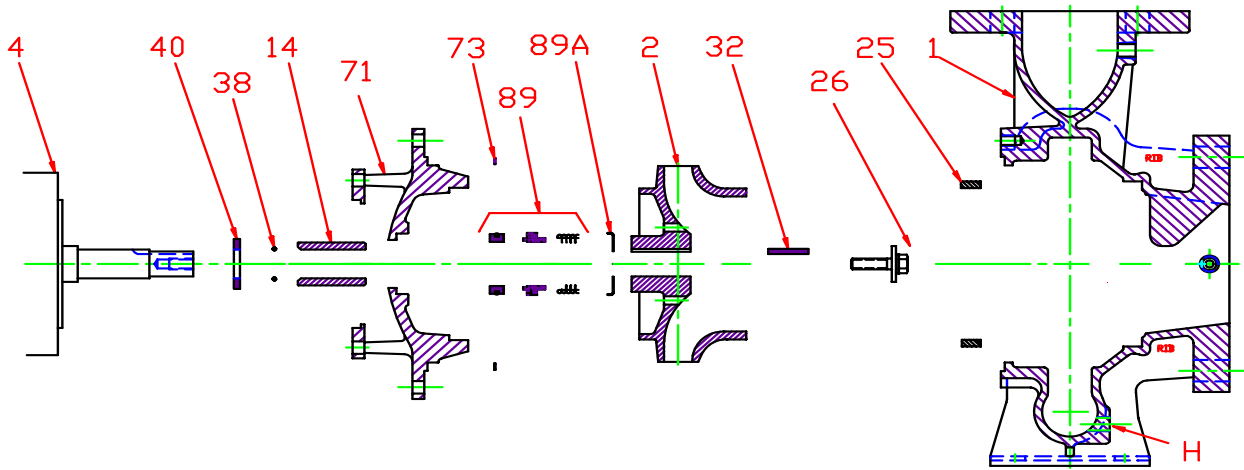

CONSTRUCTION OPTIONS				
KEY	PART NAME	STANDARD FITTED	BRONZE FITTED	ALL IRON
1	Case	Iron	Iron	Iron
2	Impeller	Iron	Bronze	Iron
14	Shaft Sleeve	Bronze	Bronze	Stainless
25	Wear Ring	Bronze	Bronze	Steel
26	Impeller Retaining Assy	Stainless	Stainless	Stainless
32	Key	Stainless	Stainless	Stainless
38	Shaft O-Ring	BUNA	BUNA	BUNA
40	Flinger	Stainless	Stainless	Stainless
71	Adapter	Iron	Iron	Iron
73	Gasket, Case	Fiber	Fiber	Fiber
89	Mechanical Seal, Type 21 BN-CM	Standard	Standard	Standard
89A	Seal Retainer	Stainless	Stainless	Stainless
H	Plug, Drain	Brass	Brass	Plated Steel

E057JM180

F15

C0571150JM