



A WILO COMPANY

MOTORPUMP™ — 1750 RPM

Iron, 60 Hz, 4 X 3 X 6.88 ANSI FLG

57 JM



MOTOR DIMENSIONS

NEMA JM FRAME 3 PHASE 1750 RPM

HP	Type	Frame	D	E	F	O	AB	BG	L	MH
1.5	ODP	JM143	3.50	2.75	2.50	6.72	5.87	5.25	5.36	0.34
2	ODP	JM145	3.50	2.75	2.50	6.72	5.87	5.50	5.11	0.34
3	ODP	JM182	4.50	3.75	2.25	8.56	6.70	5.75	6.65	0.41
5	ODP	JM184	4.50	3.75	2.75	8.56	6.70	6.25	7.33	0.41
1.5, 2	TEFC	JM145	3.50	2.75	2.50	7.00	6.25	5.06	6.34	0.34
3	TEFC	JM182	4.50	3.75	2.25	8.85	7.57	5.01	7.14	0.41
5	TEFC	JM184	4.50	3.75	2.75	8.85	7.57	5.51	7.64	0.41

DRAWING DEPICTS JM145 1HP ODP MOTOR
ALL DIMENSIONS IN INCHES

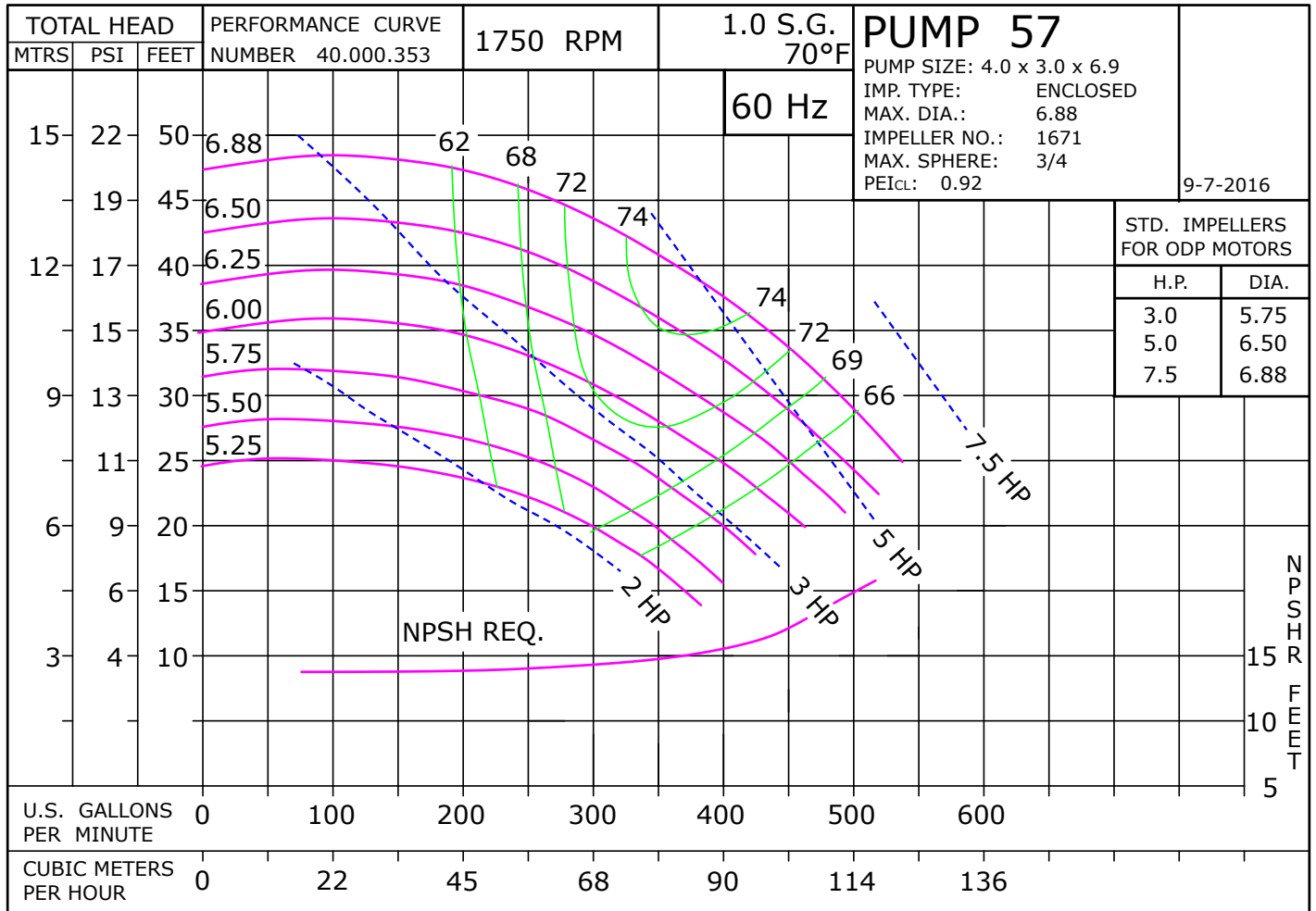
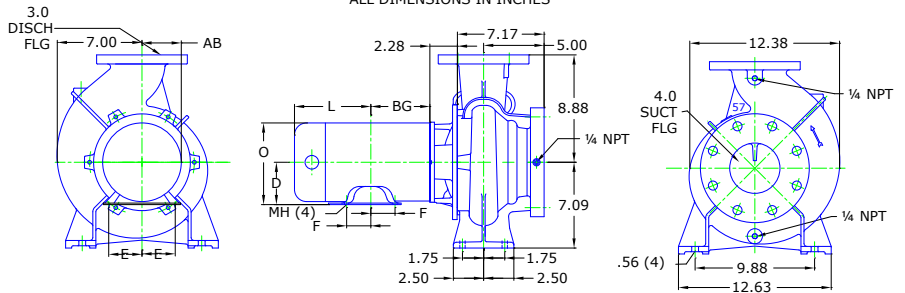

0575DP

D057JM182

0571750JM

D20

Scot Pump, A Wilo Company
+1-262-377-7000
scot.sales@wilo.com

Parts

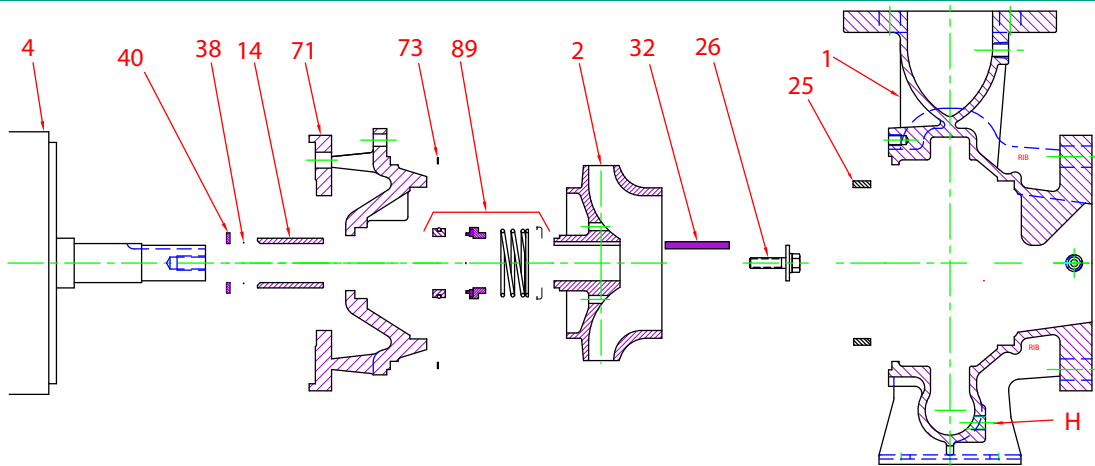

Key No.	Part Name	Part Number
1+	Case 57, Iron, 4.00 X 3.00 FLG Bronze Wear Ring and plugs	130.000.297X
2	Impeller 57, Bronze, Specify Dia., 6.87 Max 7/8" Key	137.000.222
	Impeller 57, Iron, Specify Dia., 6.87 Max 7/8" Key	137.000.122
4	Motor chart, JM140/180	See Chart
	Motor chart, JM210	See Chart
14*	Shaft sleeve, Bronze	110.000.215
	Shaft Sleeve, Stainless	110.000.373
25	Wear ring, Bronze	103.000.197
	Wear ring, Steel	103.000.218
26*	Impeller retaining assembly, Stainless	118.000.163A
32*	Key, Stainless	102.000.256
38*	O-ring, Shaft, Buna	116.000.117
	O-ring, Shaft, Viton	116.000.105
40*	Flinger, Stainless	104.000.256
71	Adapter, Iron, JM180 1-1/2" Seal, with Brass plug	132.000.339X
73*	Gasket, Case, Fiber	116.000.273
89*	Seal, 1-1/2", Type 21, BN-CARB/CM	101.000.168
	Seal, 1-1/2", Type 21, EPDM-CARB/SIL	101.000.175B
	Seal, 1-1/2", Type 21, EPDM-SIL/SIL	101.000.204A
	Seal, 1-1/2", Type 21, VN-CARB/CM	101.000.191
	Seal, 1-1/2", Type 21, VN-CARB/SIL	101.000.175
	Seal, 1-1/2", Type 21, VN-SIL/SIL	101.000.204
89A*	Seal spring retainer, Stainless	104.000.174
KIT	Repair Kit, 1-1/2" BN-CARB/CM Seal, Brz sleeve, BN O-ring	118.000.383
	Repair Kit, 1-1/2" EPDM-CARB/SIL Seal, Brz sleeve, BN O-ring	118.000.383C
	Repair Kit, 1-1/2" EPDM-SIL/SIL Seal, Brz sleeve, BN O-ring	118.000.383D
	Repair Kit, 1-1/2" VN-CARB/CM Seal, Brz sleeve, BN O-ring	118.000.383G
	Repair Kit, 1-1/2" VN-CARB/CM Seal, Stn sleeve, VN O-ring	118.000.383A
	Repair Kit, 1-1/2" VN-CARB/SIL Seal, Brz sleeve, BN O-ring	118.000.383B
	Repair Kit, 1-1/2" VN-SIL/SIL Seal, Stn sleeve, VN O-ring	118.000.383E

* Denotes components included in repair kit.

+ Includes bronze wear ring. For steel, replace suffix "X" with "X1".

Motor Charts

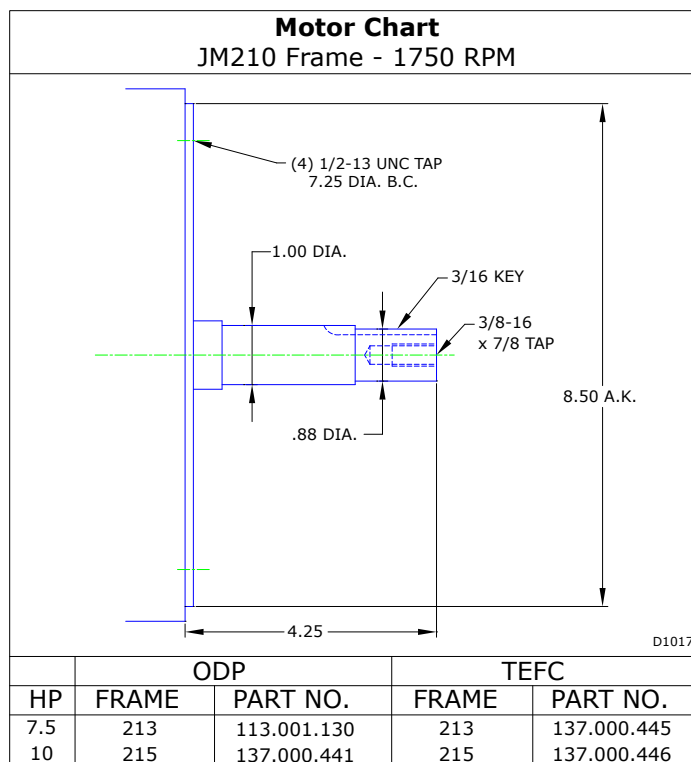
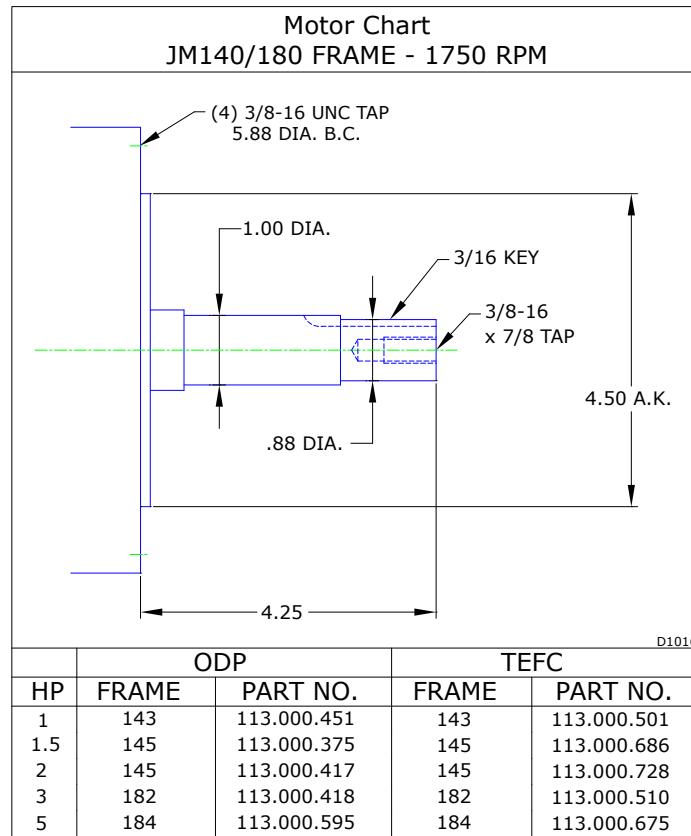

Construction Options

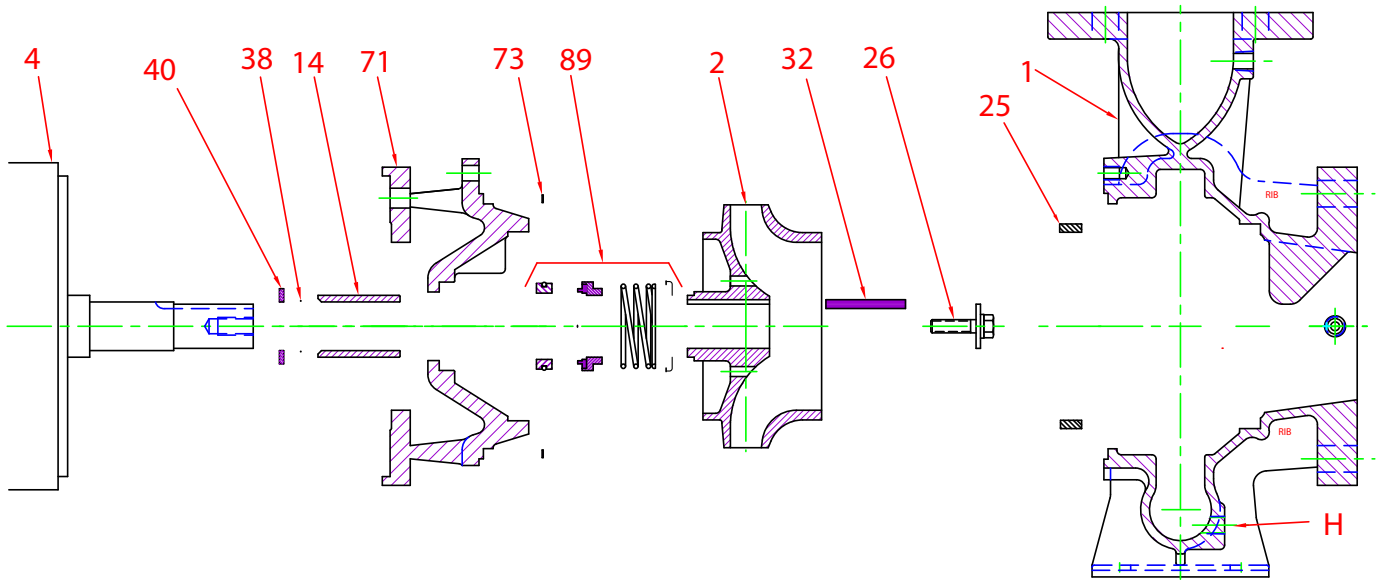

Construction Options				
Key	Part Name	Standard Fitted	Bronze Fitted	All Iron
1	Case	Iron	Iron	Iron
2	Impeller	Iron	Bronze	Iron
14	Shaft Sleeve	Bronze	Bronze	Stainless
25	Wear Ring	Bronze	Bronze	Steel
26	Impeller Retaining Assy	Stainless	Stainless	Stainless
32	Key	Stainless	Stainless	Stainless
38	Shaft O-Ring	Buna	Buna	Buna
40	Flinger	Stainless	Stainless	Stainless
71	Adapter	Iron	Iron	Iron
73	Gasket, Case	Fiber	Fiber	Fiber
89	Mechanical Seal, Type 21 BN-CM	Standard	Standard	Standard
89A*	Seal Spring Retainer	Stainless	Stainless	Stainless
H	Plug, Drain	Brass	Brass	Plated Steel

* Included with seal on 20-25 HP