

D322JM14-18

DRAWING DEPICTS 14-18JM SHP TEFC MOTOR

MOTOR DIMENSIONS

NEMA PREMIUM EFFICIENT JM FRAME 3 PHASE 1750 RPM

HP	Type	Frame	D	E	F	O	AB	BG	L	MH
1	ODP	JM143	3.50	2.75	2.00	6.75	5.42	4.25	5.07	0.34
1.5	ODP	JM145	3.50	2.75	2.50	6.77	5.12	5.38	4.12	0.34
1	TEFC	JM143	3.50	2.75	2.00	7.00	6.25	4.57	5.84	0.34
1.5	TEFC	JM145	3.50	2.75	2.50	7.00	6.25	5.06	6.34	0.34

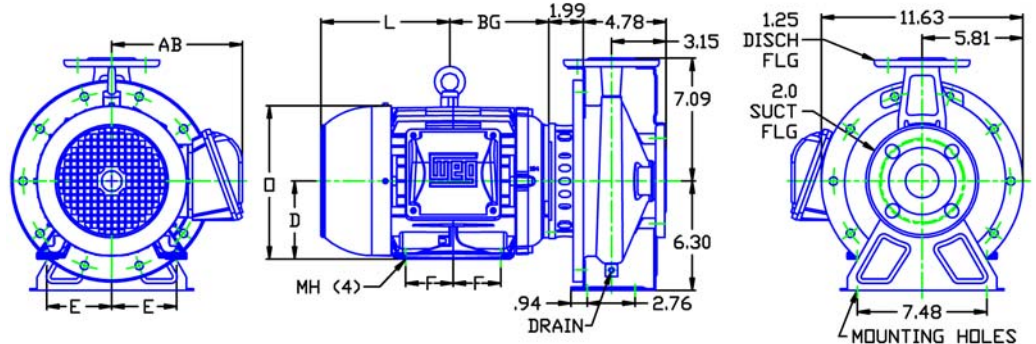

ALL DIMENSIONS IN INCHES.

DRAWING REPRESENTS APPROXIMATE PUMP DIMENSIONS. ATOCAD DRAWING TO SCALE AVAILABLE FROM FACTORY.

**PUMP TO BE
INSTALLED ONLY IN
THE HORIZONTAL
POSITION AS
SHOWN.**



32205TE

D322JM21
3221750

322 JM

3221750JM
81.002.233 D18

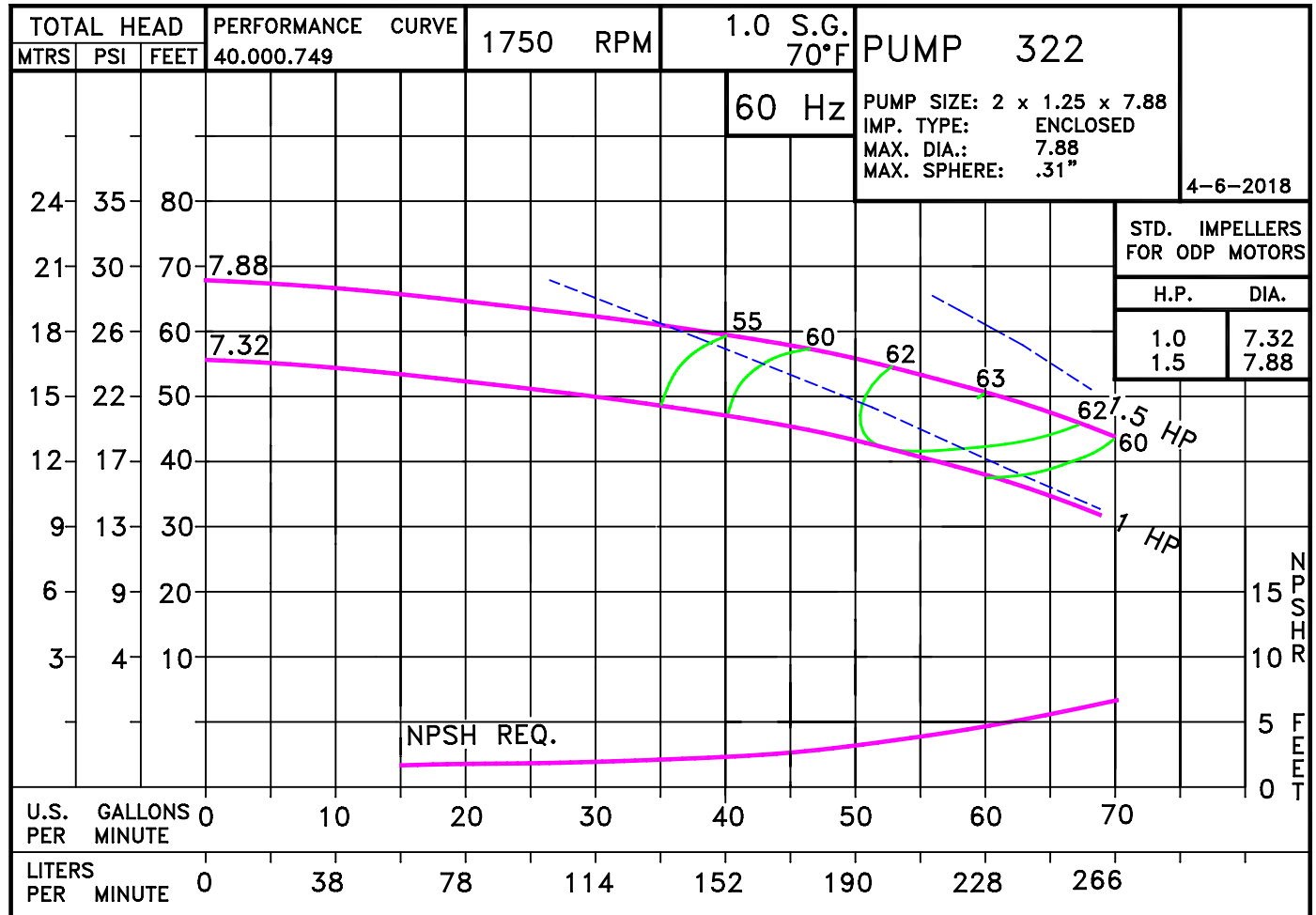

Pump 322 • 304SS • JM Frame • 1750 RPM

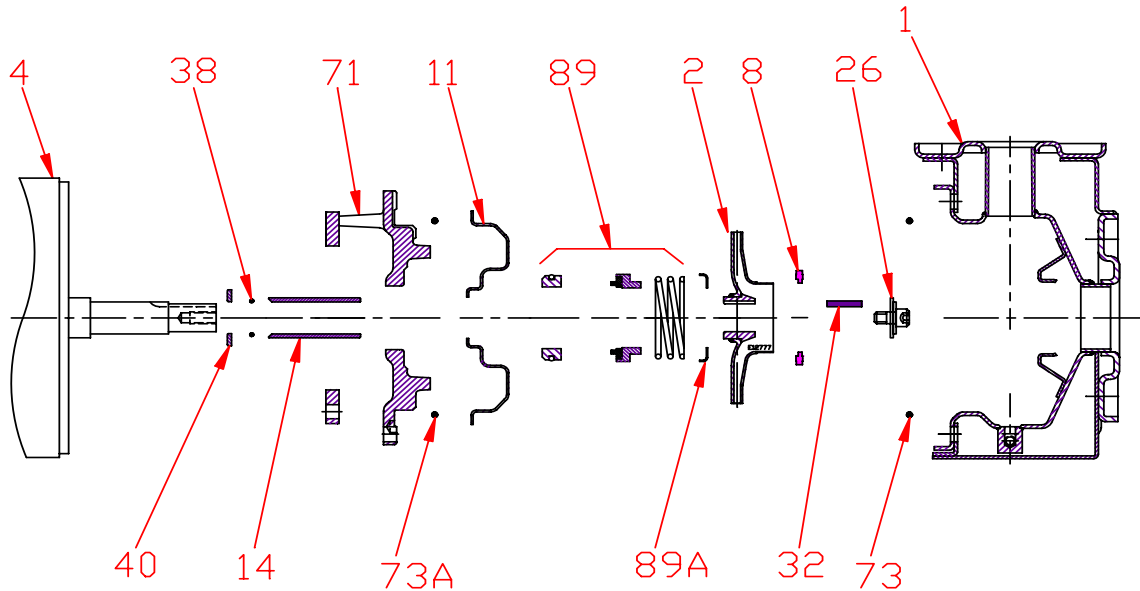

KEY NO.	PART NAME	PUMP 322
1	CASE, 304SS, 2.0 x 1.25, FLG	137.002.957
2	IMPELLER, STAINLESS, ENCLOSED, 7/8" KEYED:	
	7.32" DIA	137.002.916
	7.88" DIA	137.002.917
4	MOTOR, JM140/180	See Chart
8	RING	137.002.906
11	COVER, 304SS	137.002.919
14*	SHAFT SLEEVE, 304SS	137.002.904
26*	IMPELLER RETAINER, 304SS	118.000.111A
32*	KEY, 303SS	102.000.102
38*	O-RING, SHAFT, BUNA	116.000.117
40*	FLINGER, 304SS	104.000.165
71	ADAPTER, IRON, JM140/180	137.002.918
73*	GASKET, CASE, BUNA	137.002.922
73A*	GASKET, COVER, BUNA	137.003.013
89*	1-1/4" SEALS	
	TYPE 21, BN-CARB/CM	137.002.949
	TYPE 21, VN-CARB/CM	137.002.950
	TYPE 21, VN-CARB/SIL	137.002.952
	TYPE 21, VN-SIL/SIL	137.002.953
	TYPE 21, EPDM-CARB/SIL	137.002.951
89A	SEAL RETAINER, STAINLESS	137.002.948
--	REPAIR KITS:	
	BN-CARB/CM SEAL	118.000.675
	VN-CARB/CM SEAL	118.000.675A
	VN-CARB/SIL SEAL	118.000.675D
	VN-SIL/SIL SEAL	118.000.675B
	EPDM-CARB/SIL SEAL	118.000.675C

* DENOTES COMPONENTS INCLUDED IN REPAIR KIT.

Pump 322 • 304SS • JM Frame • 1750 RPM

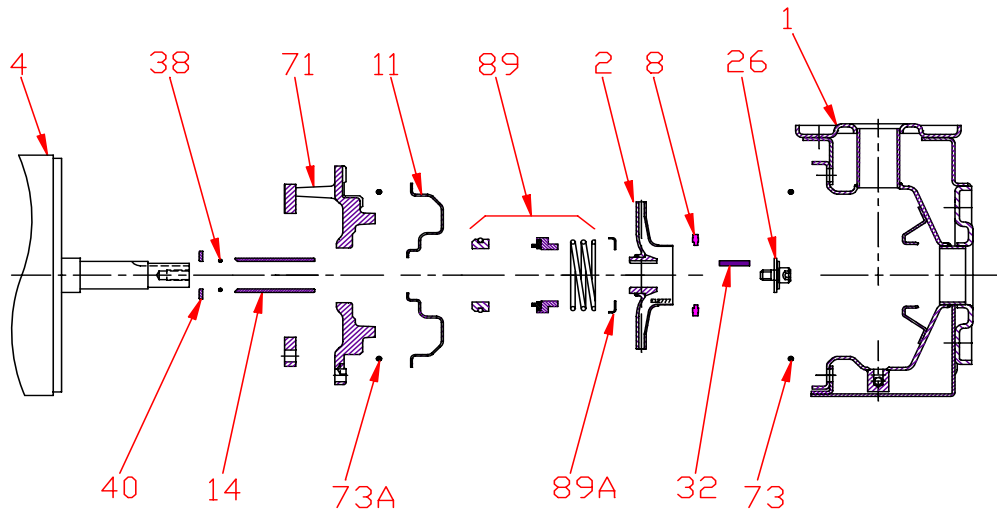

CONSTRUCTION OPTIONS		
KEY	PART NAME	STANDARD FITTED
1	Case	304SS
2	Impeller	304SS
8	Impeller Ring	POLYPHENYLENE OXIDE 20% GLASS
11	Cover	304SS
14	Sleeve	304SS
26	Retainer Assembly	304SS
32	Key	303SS
38	O-ring, Shaft	BUNA
40	Flinger	304SS
71	Motor Disc	Cast Iron
73	Gasket, Case	Buna
73A	Gasket, Cover	Buna
89	Seal Assembly	BN-CARB/CM
89A	Seal Retainer	304SS

E320JM
D18

C3221750JM