

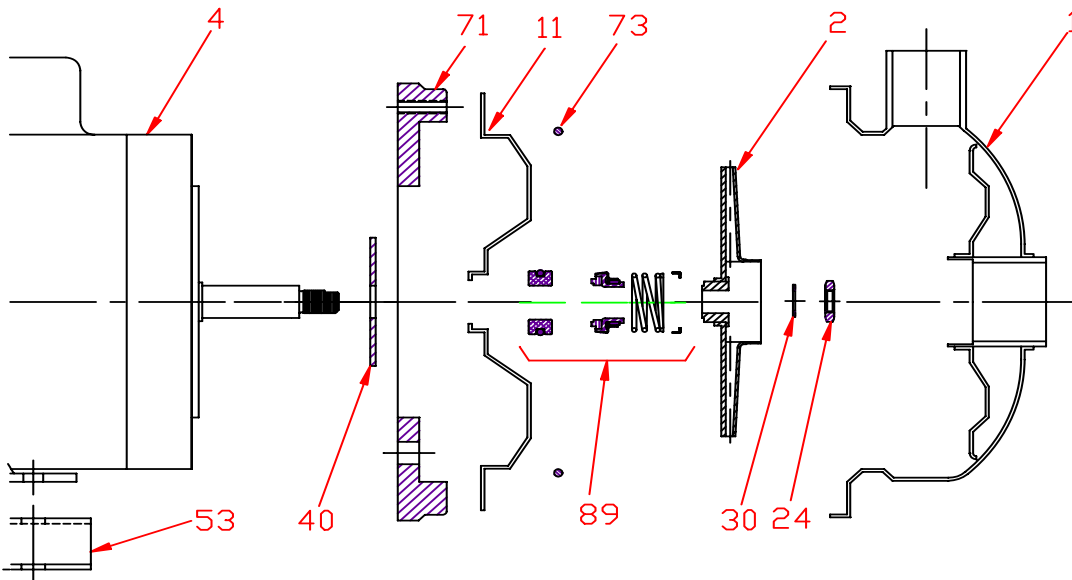

**Pump 232 • 304SS • J56 Frame • 3500 RPM**



KEY NO.	PART NAME	PUMP 232	
1	CASE, 304SS, 1.5 x 1.25, NPT	137.001.314	
2	IMPELLER, STAINLESS, ENCLOSED, 7/16" THREADED:		
	4.90" DIA	137.001.318	
	5.40" DIA	137.001.317	
	5.80" DIA	137.001.316	
	6.30" DIA	137.001.315	
4	MOTOR:		
	J56/180, 4.5" RIGID BASE J56/56, 3.5" RIGID BASE	See Chart See Chart	
11	COVER, STAINLESS	137.001.059	
24*	NUT, 304SS	137.001.349	
30*	D WASHER, 316SS	104.000.168	
40*	FLINGER, NEOPRENE	104.000.171	
53	BASE, STEEL	137.001.130	
71	DISC, IRON	137.001.046	
73*	GASKET, CASE, BUNA	137.001.121	
89*	5/8" SEALS WITH RETAINER:		
	TYPE 21, BN-CARB/SIL	137.002.401	
	TYPE 21, VN-CARB/SIL	137.002.390	
	TYPE 21, VN-SIL/SIL	137.002.406	
	TYPE 21, EPDM-CARB/SIL	137.002.258	
--	REPAIR KITS:	3 PHASE:	† 1 PHASE:
	BN-CARB/SIL SEAL	118.000.581	118.000.581.1
	VN-CARB/SIL SEAL	118.000.581E	118.000.581E.1
	VN-SIL/SIL SEAL	118.000.581F	118.000.581F.1
	EPDM-CARB/SIL SEAL	118.000.581C	118.000.581C.1

\* DENOTES COMPONENTS INCLUDED IN REPAIR KIT.

† USE 3 PHASE KIT ON 2-3 HP 1 PHASE MOTORS.

**Pump 232 • 304SS • J56 Frame • 3500 RPM**

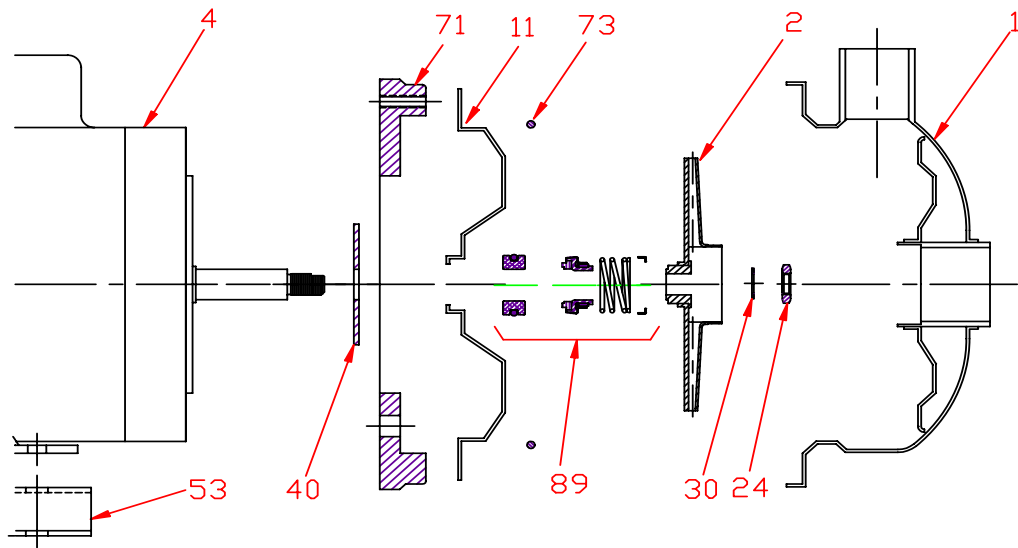

CONSTRUCTION OPTIONS		
KEY	PART NAME	STANDARD FITTED
1	Case	304SS
2	Impeller	304SS
11	Cover	304SS
24	Nut	304SS
30	D-Washer	316SS
40	Flinger	Neoprene
53	Base	Steel
71	Motor Disc	Cast Iron
73	Gasket, Case	Buna
89	Seal Assembly, BN-CARB/SIL	Standard
89A	Seal Retainer	304SS

E231J56-B

J15

C2323500J56