

MOTOR DIMENSIONS NEMA C56 FRAME 1750 RPM

HP	FRAME	ODP			TEFC		
		L	O	AB	L	O	AB
.50	C56	9.16	6.19	5.06	9.48	7.25	5.88
.75	C56	9.78	6.19	5.06	9.87	7.25	5.88

See JM frame for .75 – 1.5 HP

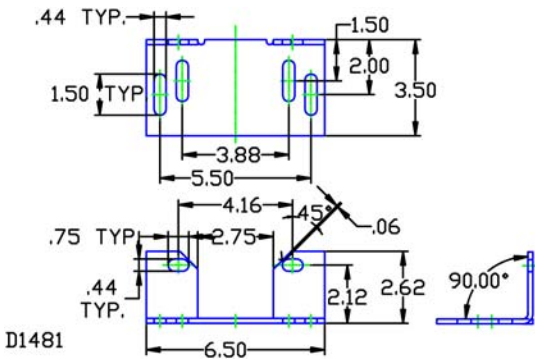

D1481

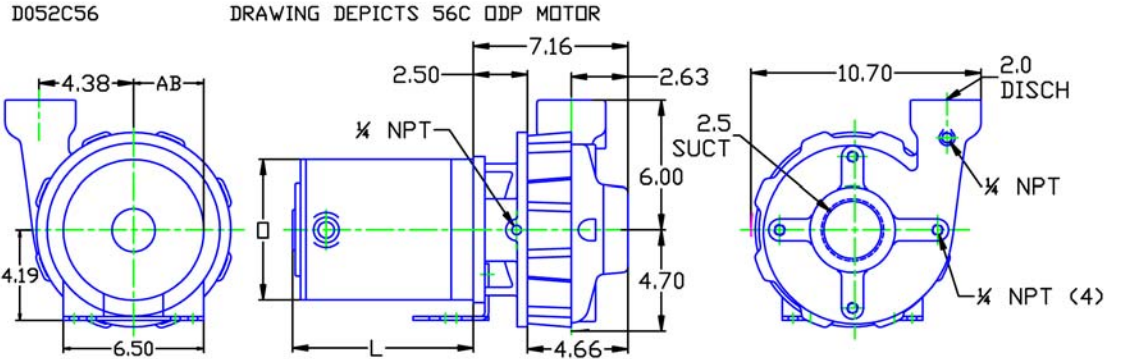

ALL DIMENSIONS IN INCHES.

DRAWING REPRESENTS APPROXIMATE PUMP DIMENSIONS. AUTOCAD DRAWINGS TO SCALE AVAILABLE FROM FACTORY.



D1481
05007DP

D052C56
0521450

52 C56

0521750C56
81.001.101 K14

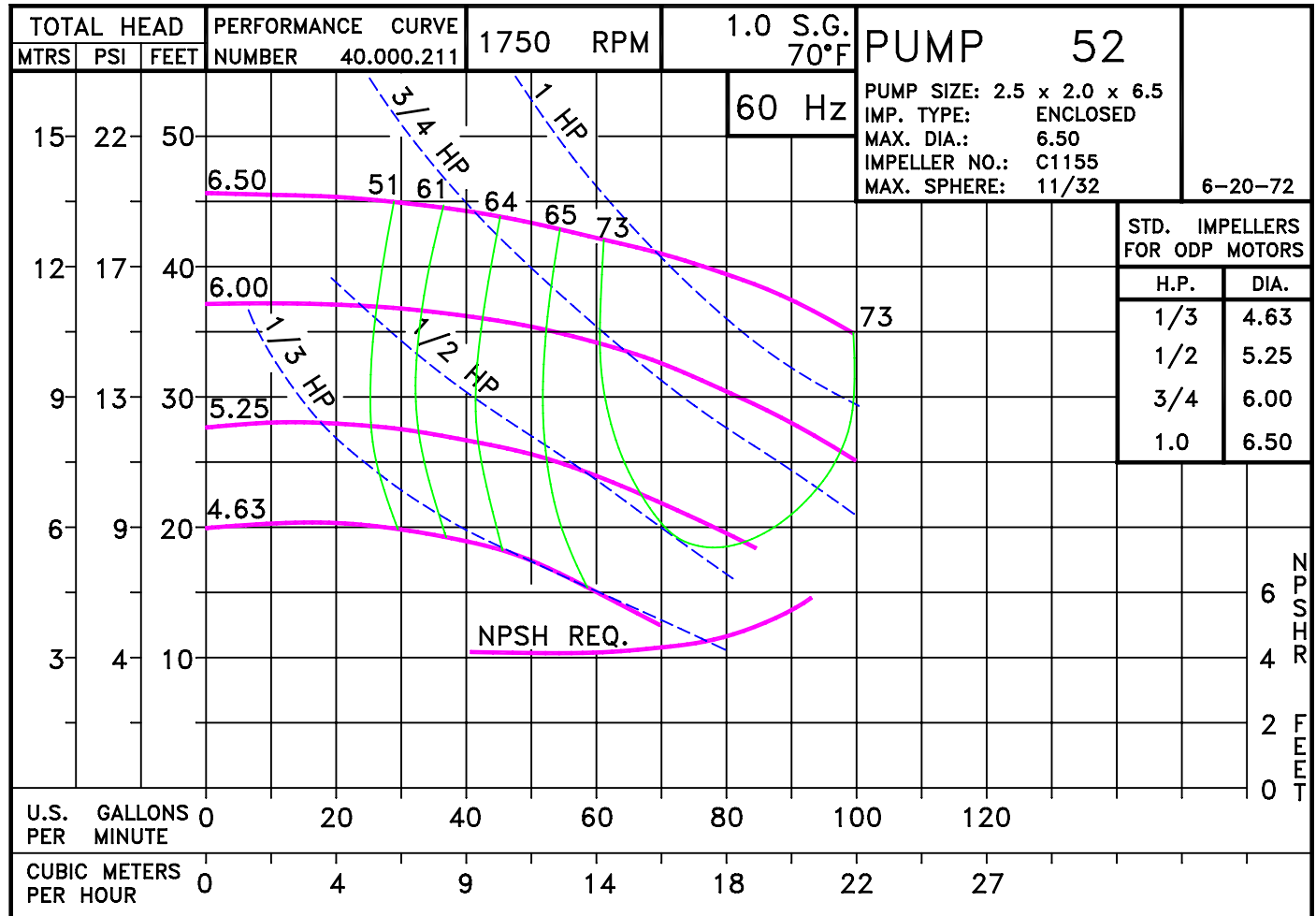

Pump 52 • Iron • C56 Frame • 1750 RPM

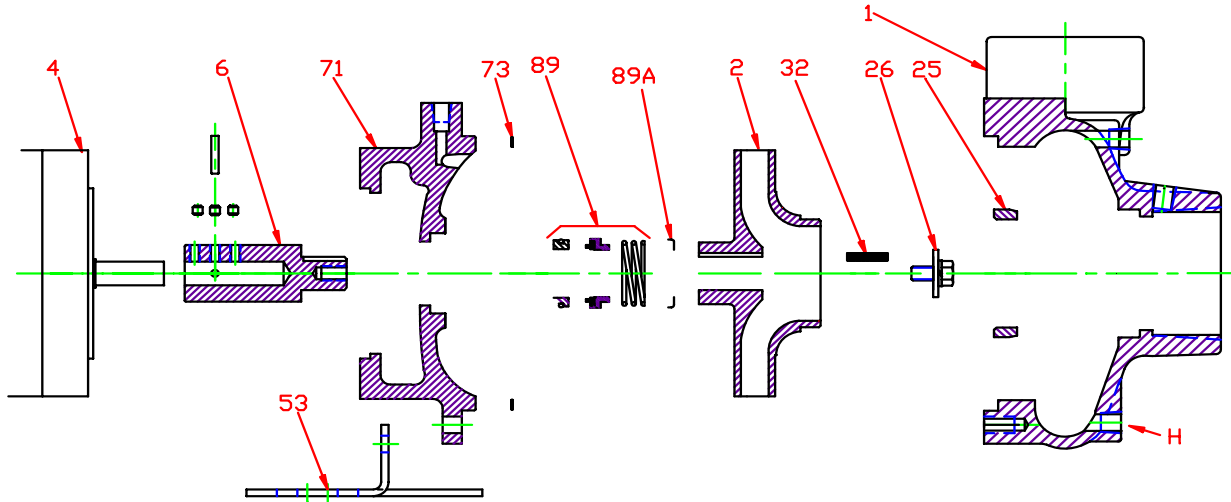

KEY NO.	PART NAME	PUMP NO. 52
1+	CASE, IRON, 2.5 x 2 NPT	130.000.219X
2	IMPELLER, 7/8" KEYED, ENCLOSED, SPECIFY DIAMETER:	
	IRON	137.000.120
	BRONZE	131.000.810
4	MOTOR, C56	See Chart
6*†	STUB SHAFT, BRONZE	135.000.165X
	STUB SHAFT, STAINLESS	135.000.174X
25	WEAR RING, BRONZE	103.000.136
	WEAR RING, STEEL	103.000.154
26*	IMPELLER RETAINER, STAINLESS	118.000.163A
32*	KEY, STAINLESS	102.000.102
53	BASE, STEEL	119.000.237D
71	ADAPTER, IRON	132.000.202X
73*	GASKET, CASE, FIBER	116.000.157
89*	1½" SEALS:	
	BN-CARB/CM	101.000.168
	VN-CARB/CM	101.000.191
	VN-CARB/SIL	101.000.175
	VN-SIL/SIL	101.000.204
	EPDM-CARB/SIL	101.000.175B
	EPDM-SIL/SIL	101.000.204A
89A*	SEAL RETAINER, STAINLESS	104.000.174
--	° REPAIR KITS:	
	BN-CARB/CM SEAL	118.000.382
	VN-CARB/CM SEAL (S)	118.000.382A
	VN-CARB/SIL SEAL	118.000.382B
	VN-SIL/SIL SEAL (S)	118.000.382D
	EPDM-CARB/SIL SEAL	118.000.382C
	EPDM-SIL/SIL SEAL	118.000.382E

* DENOTES COMPONENTS INCLUDED IN REPAIR KIT.

+ INCLUDES BRONZE WEAR RING. FOR STEEL WEAR RING, REPLACE SUFFIX "X" WITH "X1".

° ALL REPAIR KITS INCLUDE THE BRONZE STUB SHAFT EXCEPT THE (S) INDICATED, WHICH IS STAINLESS.

† INCLUDES SET SCREWS AND PIN

Pump 52 • Iron • C56 Frame • 1750 RPM

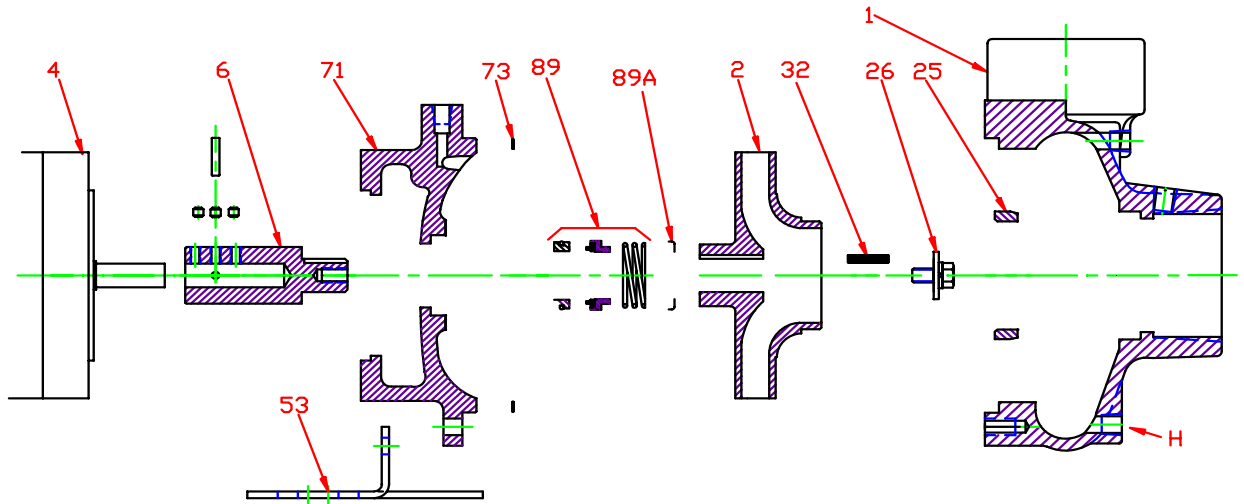

CONSTRUCTION OPTIONS

KEY	PART NAME	STANDARD FITTED	BRONZE FITTED	ALL IRON
1	Case	Iron	Iron	Iron
2	Impeller	Iron	Bronze	Iron
6	Shaft Stub	Bronze	Bronze	Stainless
25	Wear Ring	Bronze	Bronze	Steel
26	Impeller Retaining Assy	Stainless	Stainless	Stainless
32	Key	Stainless	Stainless	Stainless
53	Base	Steel	Steel	Steel
71	Adapter	Iron	Iron	Iron
73	Gasket, Case	Fiber	Fiber	Fiber
89	Mechanical Seal, Type 21 BN-CM	Standard	Standard	Standard
89A	Seal Spring Retainer	Stainless	Stainless	Stainless
H	Plug, Drain	Brass	Brass	Plated Steel

E054C56

H12

C0521750C56