

MOTOR DIMENSIONS

NEMA PREMIUM EFFICIENT JM FRAME 3 PHASE 3500 RPM

HP	Type	Frame	D	E	F	O	AB	BG	L	MH
3	ODP	JM145	3.50	2.75	2.50	6.77	5.61	5.38	4.12	0.34
5	ODP	JM182	4.50	3.75	2.25	8.44	6.74	5.75	5.12	0.41
7.5	ODP	JM184	4.50	3.75	2.25	8.44	6.74	5.75	6.56	0.41
3	TEFC	JM182	4.50	3.75	2.25	8.85	7.57	5.01	7.14	.41
5, 7.5	TEFC	JM184	4.50	3.75	2.75	8.85	7.57	5.51	7.64	.41

D236JM182

DRAWING DEPICTS 182JM SHP ODP MOTOR

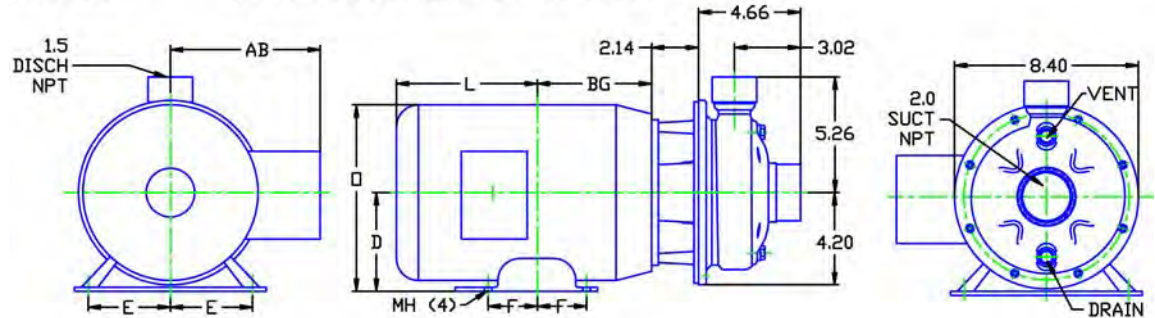

ALL DIMENSIONS IN INCHES.

DRAWING REPRESENTS APPROXIMATE PUMP DIMENSIONS. ATOCAD DRAWING TO SCALE AVAILABLE FROM FACTORY.



Drinking Water
System Component
NSF/ANSI 61
ALSO CLFD IN
ACCORDANCE WITH
NSF/ANSI 372



PUMP TO BE INSTALLED ONLY
IN HORIZONTAL POSITION AS SHOWN.

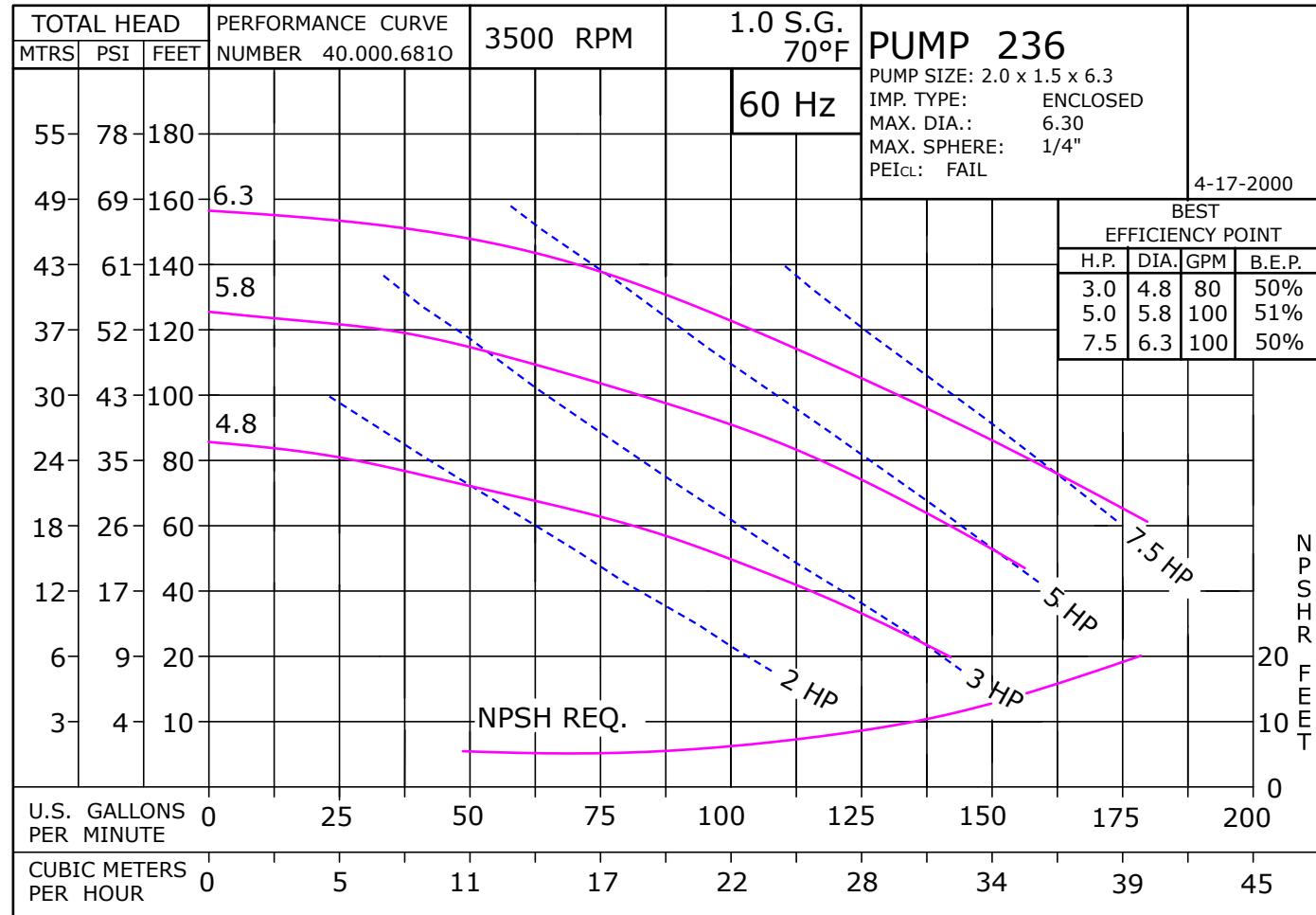

23675DP

D236JM182
2363500

236 JM

2363500JM
81.001805 M19

Pump 236 • 304SS • JM Frame • 3500 RPM

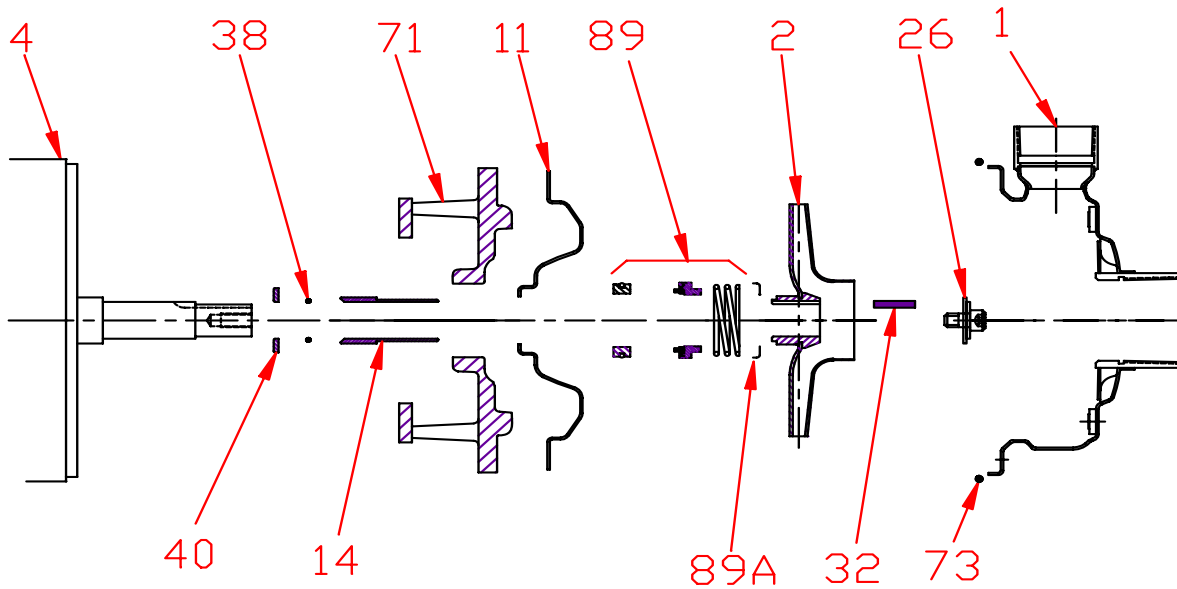

KEY NO.	PART NAME	PUMP 236
1	CASE, 304SS, 2.0 x 1.5, NPT	137.001.457
2	IMPELLER, STAINLESS, ENCLOSED, 7/8" KEYED:	
	4.80" DIA	137.001.474
	5.80" DIA	137.001.473
	6.30" DIA	137.001.458
4	MOTOR, JM140/180	See Chart
11	COVER, 304SS	137.001.459
14*	SHAFT SLEEVE, 304SS	137.001.476
26*	IMPELLER RETAINER, 304SS	118.000.111A
32*	KEY, 303SS	102.000.102
38*	O-RING, SHAFT, BUNA	116.000.117
40*	FLINGER, 304SS	104.000.165
71	DISC, IRON	137.001.435
73*	GASKET, CASE, BUNA	137.001.121
89*	1-1/8" SEALS	
	TYPE 21, BN-CARB/CM	137.001.079
	TYPE 21, VN-CARB/CM	137.001.324
	TYPE 21, VN-CARB/SIL	137.001.669
	TYPE 21, VN-SIL/SIL	137.001.546
	TYPE 21, EPDM-CARB/SIL	137.001.490
89A	SEAL RETAINER, STAINLESS	137.001.477A
--	REPAIR KITS:	
	BN-CARB/CM SEAL	118.000.605
	VN-CARB/CM SEAL	118.000.605A
	VN-CARB/SIL SEAL	118.000.605D
	VN-SIL/SIL SEAL	118.000.605B
	EPDM-CARB/SIL SEAL	118.000.605C

* DENOTES COMPONENTS INCLUDED IN REPAIR KIT.

Pump 236 • 304SS • JM Frame • 3500 RPM

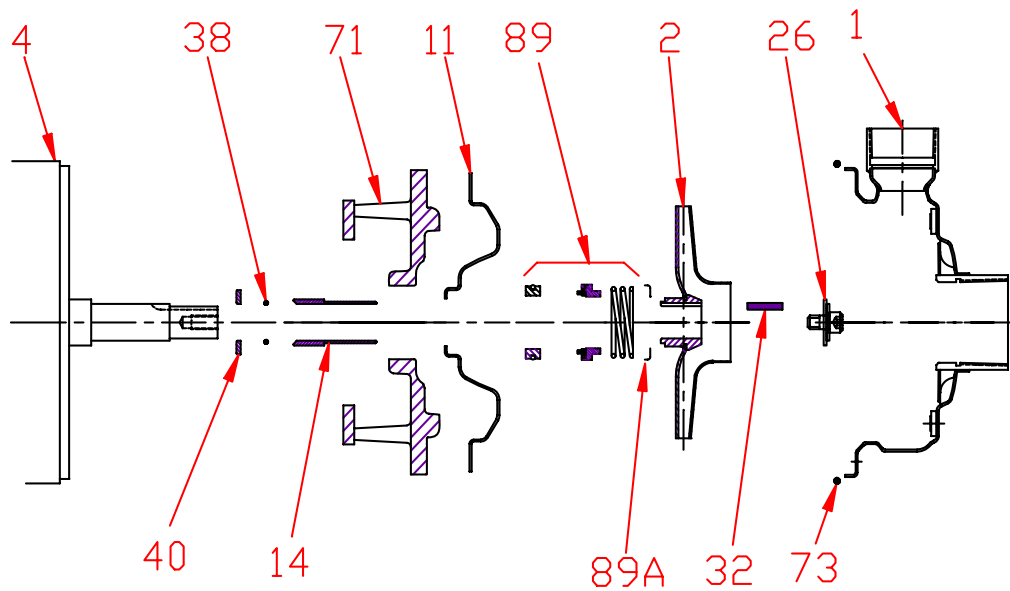

CONSTRUCTION OPTIONS		
KEY	PART NAME	STANDARD FITTED
1	Case	304SS
2	Impeller	304SS
11	Cover	304SS
14	Sleeve	304SS
26	Retainer Assembly	304SS
32	Key	303SS
38	O-ring, Shaft	BUNA
40	Flinger	304SS
71	Motor Disc	Cast Iron
73	Gasket, Case	Buna
89	Seal Assembly	BN-CARB/CM
89A	Seal Retainer	304SS

E236JM

A15

C2363500JM