



A WILO COMPANY

MOTORPUMP™ — 1750 RPM

Iron, 60 Hz, 2.5 X 2 X 6.5 NPT

52 JM



MOTOR DIMENSIONS

NEMA JM FRAME 3 PHASE 1750 RPM

HP	Type	Frame	D	E	F	O	AB	BG	L	MH
1	ODP	JM143	3.50	2.75	2.00	6.72	5.87	4.75	4.70	0.34
1.5	ODP	JM143	3.50	2.75	2.50	6.72	5.87	5.25	5.36	0.34
1	TEFC	JM143	3.50	2.75	2.00	7.00	6.25	4.57	5.84	0.34
1.5	TEFC	JM145	3.50	2.75	2.50	7.00	6.25	5.06	6.34	0.34

See C56 frame for 1/2, 3/4 HP

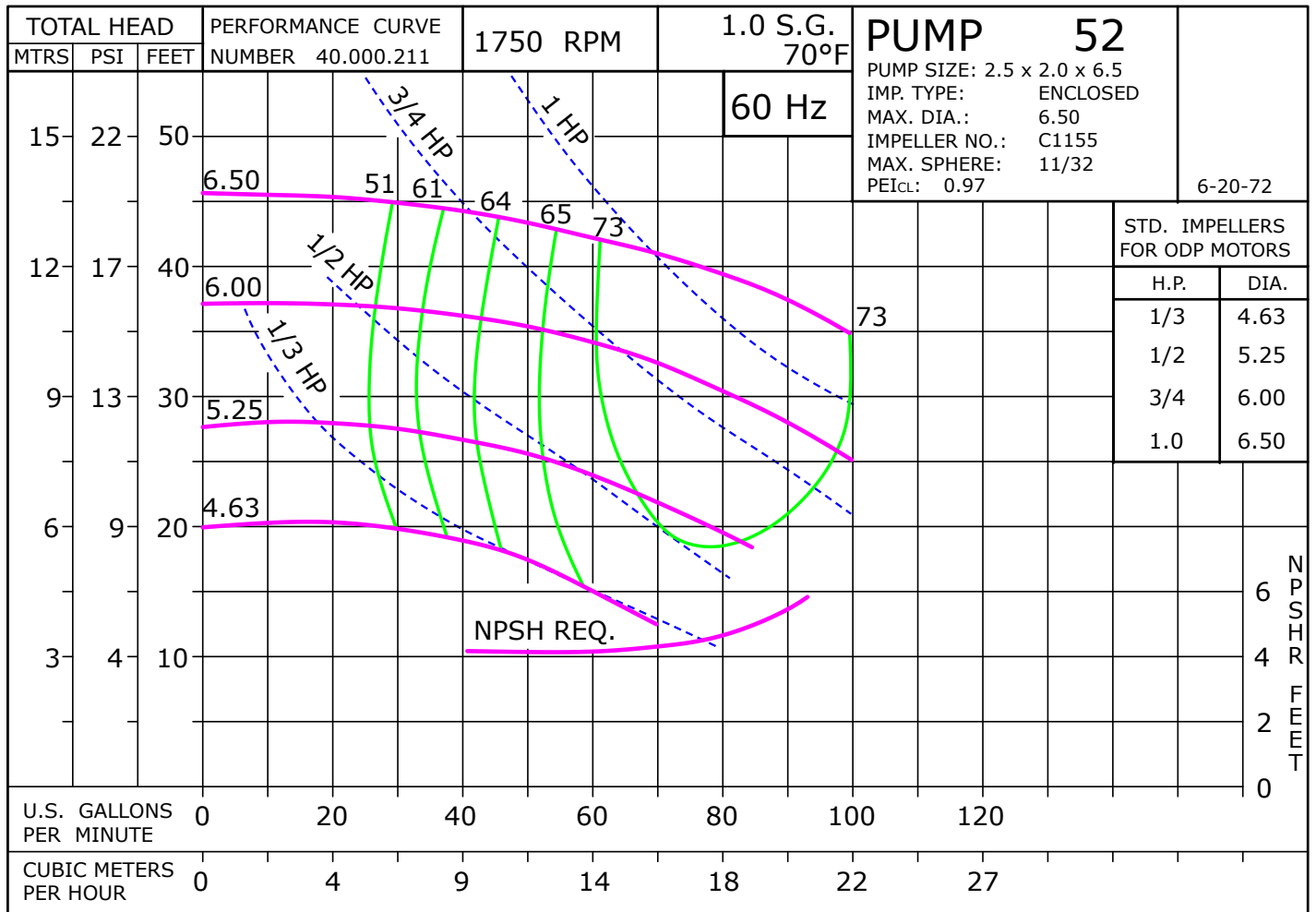
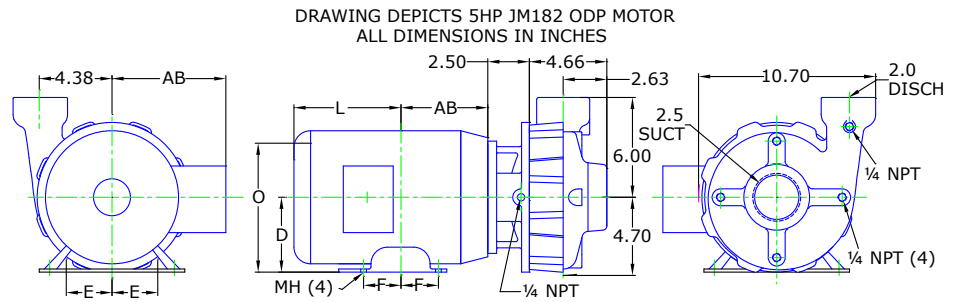

Parts

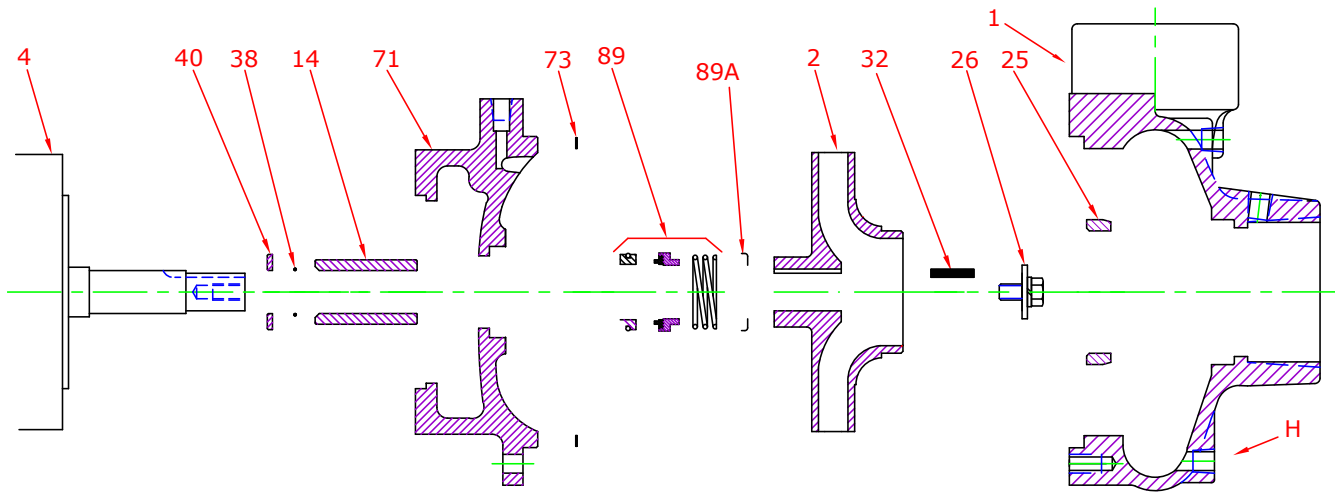

Key	Part Name	Part Number
1+	Case 52, Iron, 2.50 X 2.00 NPT Bronze Wear Ring and plugs	130.000.219X
2	Impeller 52, Bronze Specify Dia., 6.50 Max 7/8" Key	131.000.810
	Impeller 52, Iron, Specify Dia., 6.50 Max 7/8" Key	137.000.120
4	Motor chart, JM140/180	See Chart
	Motor chart, JM210	See Chart
14*	Shaft sleeve, Bronze	110.000.178
	Shaft sleeve, Stainless	110.000.192
25	Wear ring, Bronze	103.000.136
	Wear ring, Steel	103.000.154
26*	Impeller retaining assembly, Stainless	118.000.163A
32*	Key, Stainless	102.000.102
38*	O-ring, Shaft, Buna	116.000.117
	O-ring, Shaft, Viton	116.000.105
40*	Flinger, Stainless	104.000.165
71	Adapter, Iron, JM140/180 1-1/2" Seal, with Brass plug	132.000.202X
	Adapter, Iron, JM210 1-1/2" Seal, with Brass plug	132.000.213X
73*	Gasket, Case, Fiber	116.000.157
89*	Seal, 1-1/2", Type 21, BN-CARB/CM	101.000.168
	Seal, 1-1/2", Type 21, EPDM-CARB/SIL	101.000.175B
	Seal, 1-1/2", Type 21, EPDM-SIL/SIL	101.000.204A
	Seal, 1-1/2", Type 21, VN-CARB/CM	101.000.191
	Seal, 1-1/2", Type 21, VN-CARB/SIL	101.000.175
	Seal, 1-1/2", Type 21, VN-SIL/SIL	101.000.204
89A*	Seal spring retainer, Stainless	104.000.174
KIT	Repair Kit, 1-1/2" BN-CARB/CM Seal, Brz sleeve, BN O-ring	118.000.344
	Repair Kit, 1-1/2" EPDM-CARB/SIL Seal, Brz sleeve, BN O-ring	118.000.344C
	Repair Kit, 1-1/2" EPDM-SIL/SIL Seal, Brz sleeve, BN O-ring	118.000.344D
	Repair Kit, 1-1/2" VN-CARB/CM Seal, Brz sleeve, BN O-ring	118.000.344K
	Repair Kit, 1-1/2" VN-CARB/CM Seal, Stn sleeve, VN O-ring	118.000.344A
	Repair Kit, 1-1/2" VN-CARB/SIL Seal, Brz sleeve, BN O-ring	118.000.344B
	Repair Kit, 1-1/2" VN-SIL/SIL Seal, Stn sleeve, VN O-ring	118.000.344F

* Denotes components included in repair kit.

+ Includes bronze wear ring. For steel, replace suffix "X" with "X1".

Motor Charts

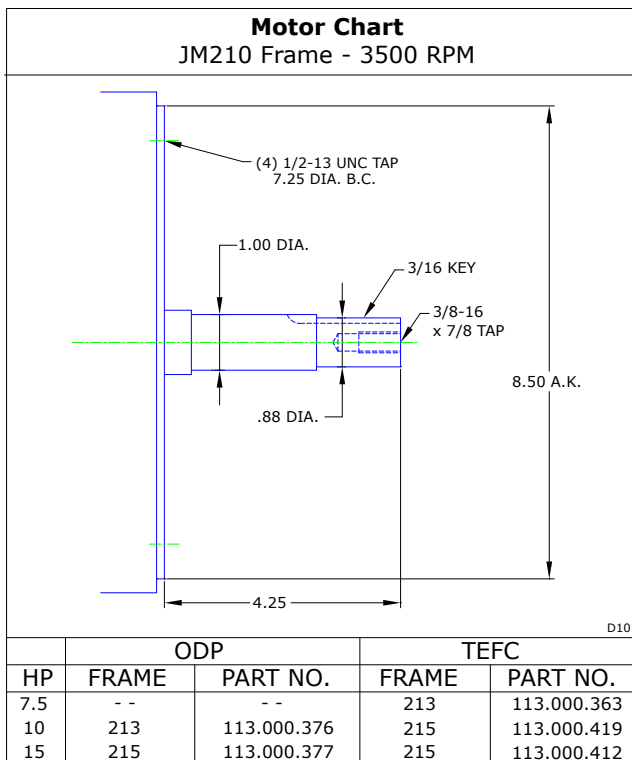
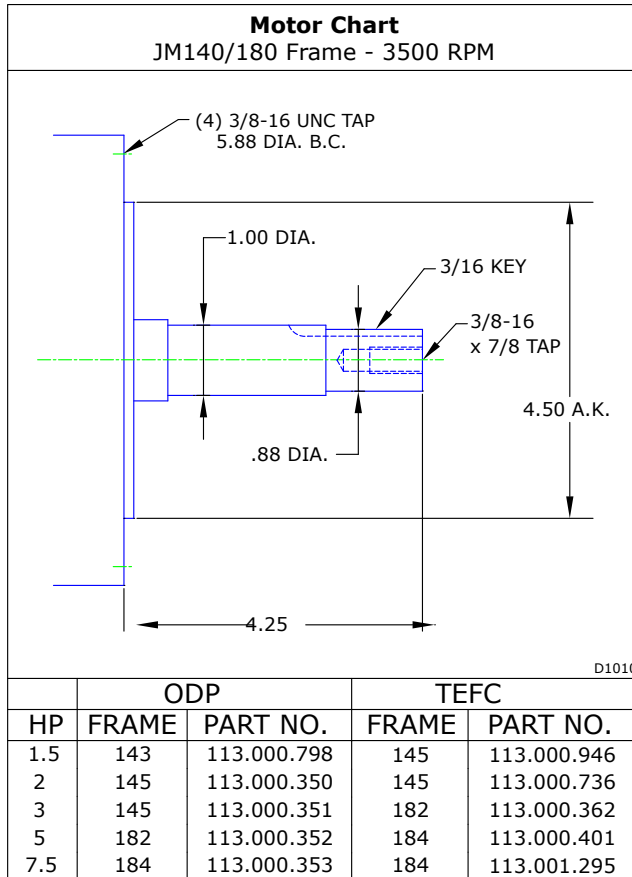

Construction Options

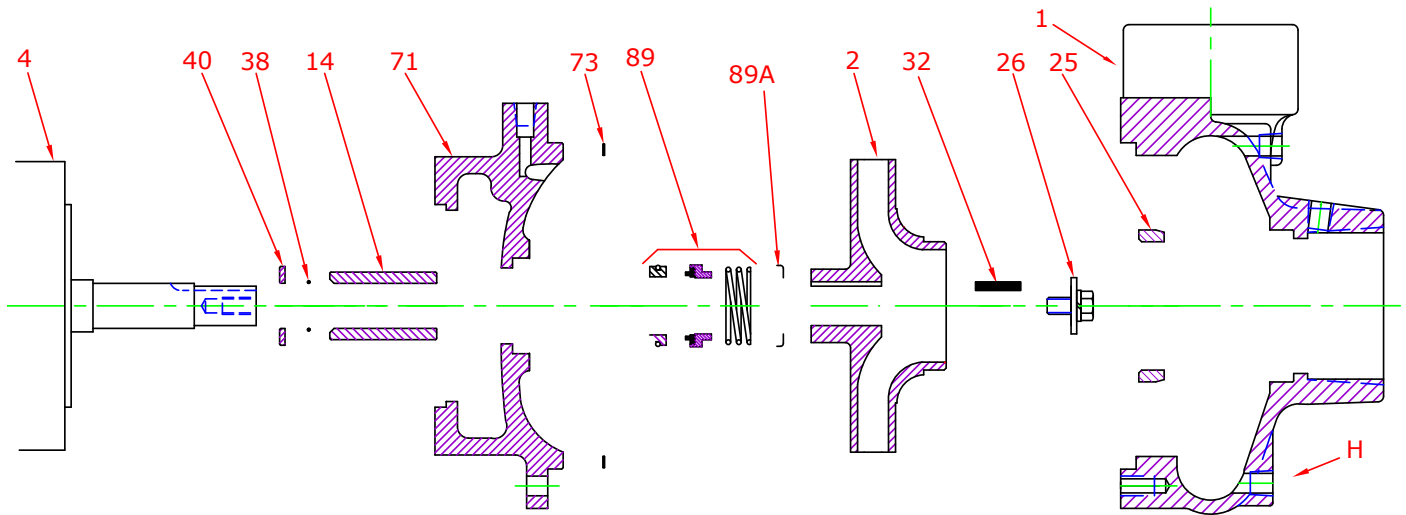

Construction Options				
Key	Part Name	Standard Fitted	Bronze Fitted	All Iron
1	Case	Iron	Iron	Iron
2	Impeller	Iron	Bronze	Iron
14	Shaft Sleeve	Bronze	Bronze	Stainless
25	Wear Ring	Bronze	Bronze	Steel
26	Impeller Retaining Assembly	Stainless	Stainless	Stainless
32	Key	Stainless	Stainless	Stainless
38	O-Ring, Shaft	Buna	Buna	Buna
40	Flinger	Stainless	Stainless	Stainless
71	Adapter	Iron	Iron	Iron
73	Gasket, Case	Fiber	Fiber	Fiber
89	Mechanical Seal, Type 21 BN-CM	Standard	Standard	Standard
89A	Seal Retainer	Stainless	Stainless	Stainless
H	Plug, Drain	Brass	Brass	Plated Steel