

MOTOR DIMENSIONS

NEMA JP FRAME 3 PHASE 1750 RPM

HP	Type	Frame	D	E	F	O	AB	BG	L	MH
15	ODP	JP254	6.25	5.00	4.13	11.03	8.17	8.91	6.69	.53
20	ODP	JP256	6.25	5.00	5.00	11.03	8.66	9.78	8.32	.53
25	ODP	JP284	7.00	5.50	4.75	13.07	11.37	9.53	10.07	.53
30	ODP	JP286	7.00	5.50	4.75	13.07	11.37	10.28	10.82	.53
15	TEFC	JP254	6.25	5.00	4.13	12.76	10.48	8.13	10.84	.53
20	TEFC	JP256	6.25	5.00	5.00	12.76	10.48	9.01	11.70	.53
25	TEFC	JP284	7.00	5.50	4.75	14.11	11.07	9.26	12.29	.53
30	TEFC	JP286	7.00	5.50	5.50	14.11	11.07	10.02	13.04	.53

D267JP256

DRAWING DEPICTS JP256 20HP ODP MOTOR

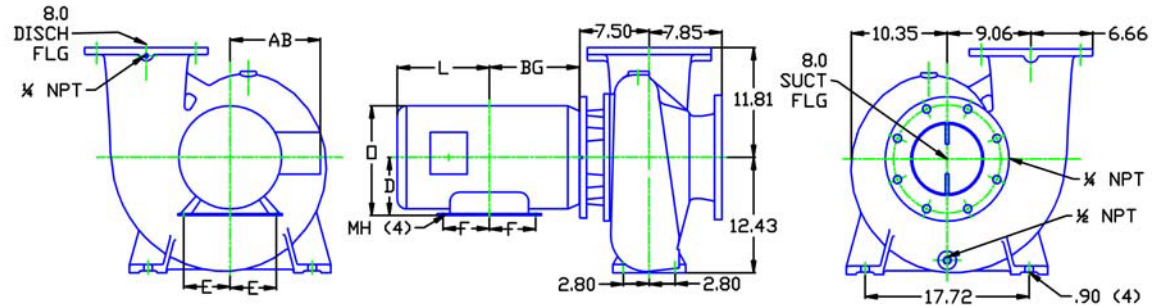

ALL DIMENSIONS IN INCHES.

DRAWING REPRESENTS APPROXIMATE PUMP DIMENSIONS. AUTOCAD DRAWING TO SCALE AVAILABLE FROM FACTORY.



26720TE

D267JP256
2671750

267 JP

2671750JP
81.001.800 C22

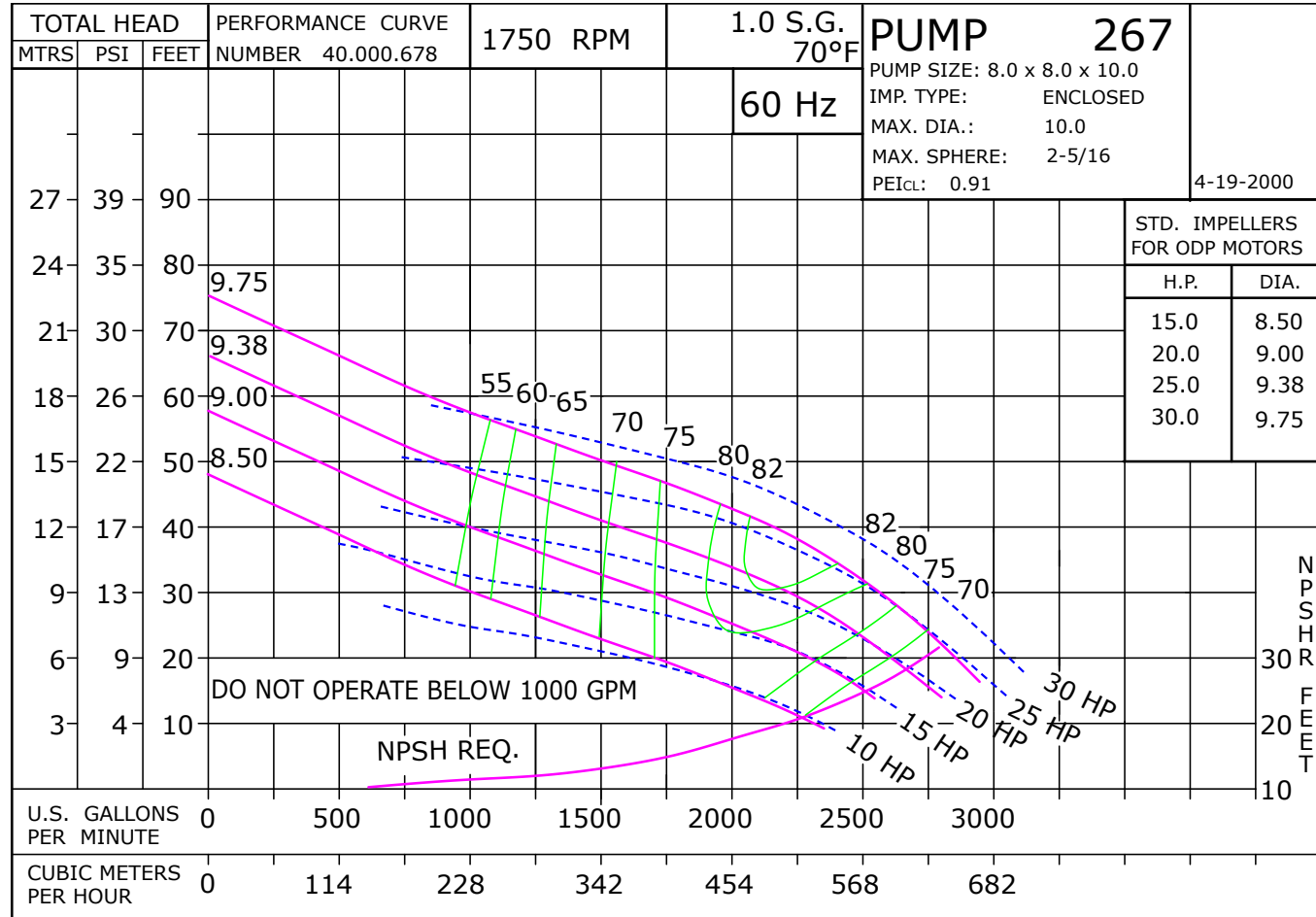

Pump 267 • Iron • JP Frame • 1750 RPM

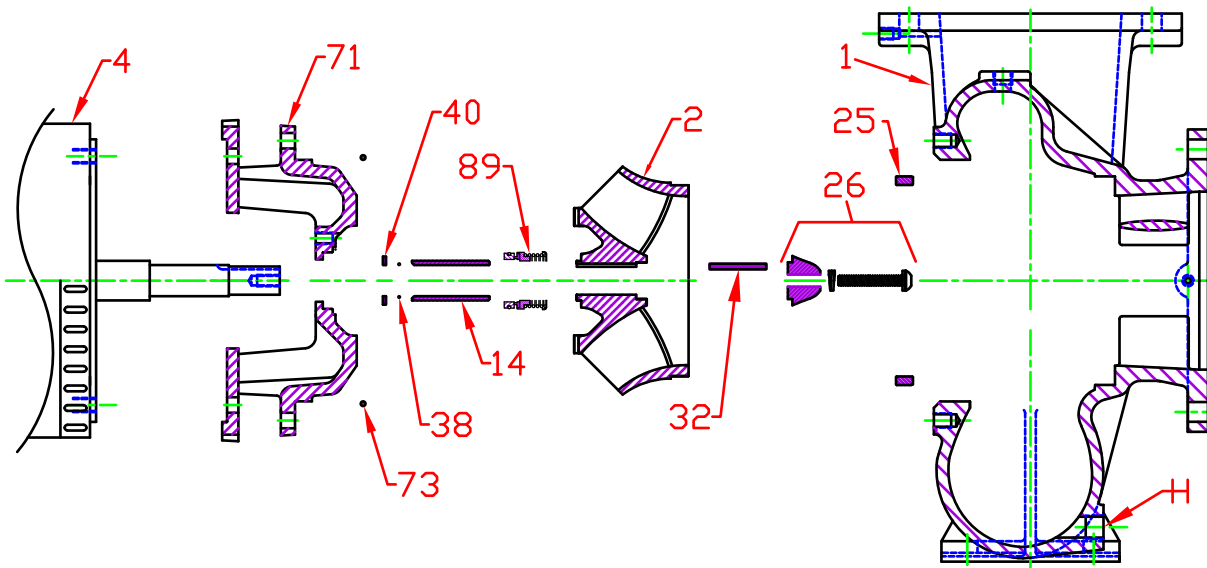

KEY NO.	PART NAME	PUMP NO. 267
1+	CASE, IRON, 8 x 8 FLG	137.001.344X
2	IMPELLER, 1¼" KEYED, ENCLOSED	IRON
	8.50" DIA	137.001.345E
	9.00" DIA	137.001.345C
	9.38" DIA	137.001.345F
	9.75" DIA	137.001.345
4	MOTOR, JP210/250	See Chart
	MOTOR, JP280/320	See Chart
14*	SHAFT SLEEVE, BRONZE	110.000.398
	SHAFT SLEEVE, STAINLESS	110.000.360
25	WEAR RING, CASE, BRONZE	137.001.348
	WEAR RING, CASE, STEEL	137.001.494
26*	IMPELLER RETAINING ASSEMBLY	118.000.641
32*	KEY, STAINLESS	102.000.284
38*	O-RING, SHAFT, BUNA	116.000.218
	O-RING, SHAFT, VITON	116.000.218A
40*	FLINGER, STAINLESS	104.000.200
71	ADAPTER, IRON, JP210/250	137.001.364X
	ADAPTER, IRON, JP280/320	137.001.346X
73*	GASKET, CASE, O-RING	137.001.347
89*	1¼" SEALS:	
	BN-CARB/CM	101.000.196
	VN-CARB/CM	101.000.216
	VN-CARB/SIL	101.000.221
	VN-SIL/SIL	101.000.231
	EPDM-CARB/SIL	101.000.196B
--	EPDM-SIL/SIL	137.001.555
	° REPAIR KITS:	
	BN-CARB/CM SEAL	118.000.598
	VN-CARB/CM SEAL (S)	118.000.598A
	VN-CARB/SIL SEAL	118.000.598B
	VN-SIL/SIL SEAL (S)	118.000.598C
	EPDM-CARB/SIL SEAL	118.000.598D
EPDM-SIL/SIL SEAL	118.000.598E	

* DENOTES COMPONENTS INCLUDED IN REPAIR KIT.
 + INCLUDES BRONZE WEAR RING.
 ° THE REPAIR KIT INCLUDES THE BRONZE SHAFT SLEEVE AND NUT EXCEPT THE (S) INDICATED, WHICH IS STAINLESS WITH VITON SHAFT O-RING.

Pump 267 • Iron • JP Frame • 1750 RPM

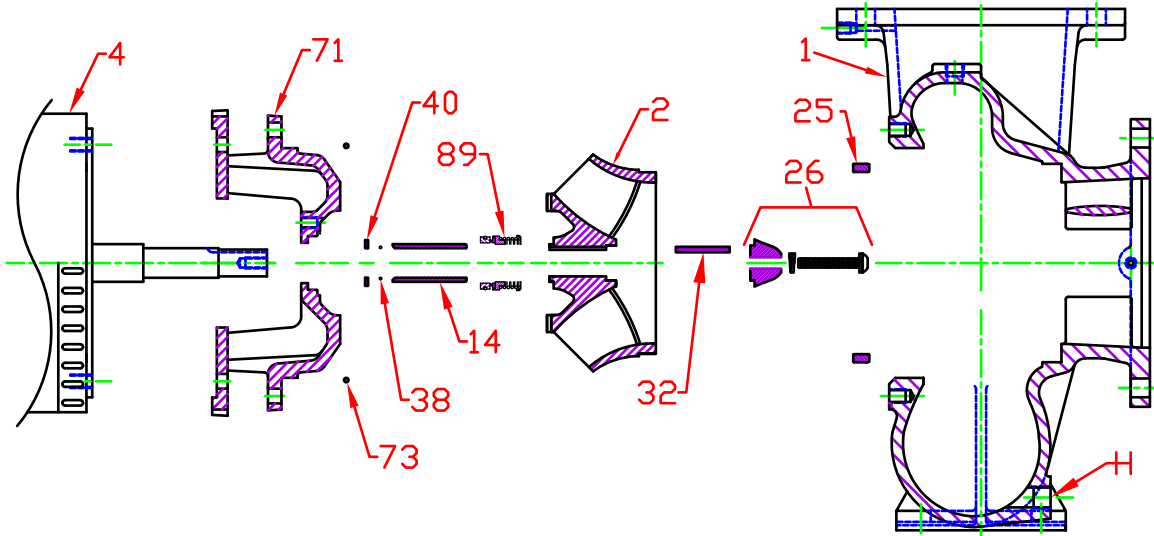

CONSTRUCTION OPTIONS			
KEY	PART NAME	STANDARD FITTED	ALL IRON
1	Case	Iron	Iron
2	Impeller	Iron	Iron
14	Shaft Sleeve	Bronze	Stainless
25	Wear Ring, Case	Bronze	Steel
26	Impeller Retaining Assembly	Stainless	Stainless
32	Key	Stainless	Stainless
38	Shaft O-Ring	BUNA	BUNA
40	Flinger	Stainless	Stainless
71	Adapter	Iron	Iron
73	Gasket, Case, O-Ring	BUNA	BUNA
89	Mechanical Seal, Type 21 BN-CM	Standard	Standard
H	Plug	Brass	Plated Steel

E267JP
C22

C2671750JP