

MOTOR DIMENSIONS NEMA J56 FRAME 3500 RPM

HP	FRAME	TYPE	3PH			1PH		
			L	O	AB	L	O	AB
.33	J56	ODP	9.27	7.75	3.09	8.81	9.60	3.31
.50	J56	ODP	10.52	7.75	3.09	9.06	9.60	3.31
.75	J56	ODP	11.02	7.75	3.09	9.56	9.60	3.31

D232J561750

DRAWING DEPICTS J56 1PHASE ODP MOTOR

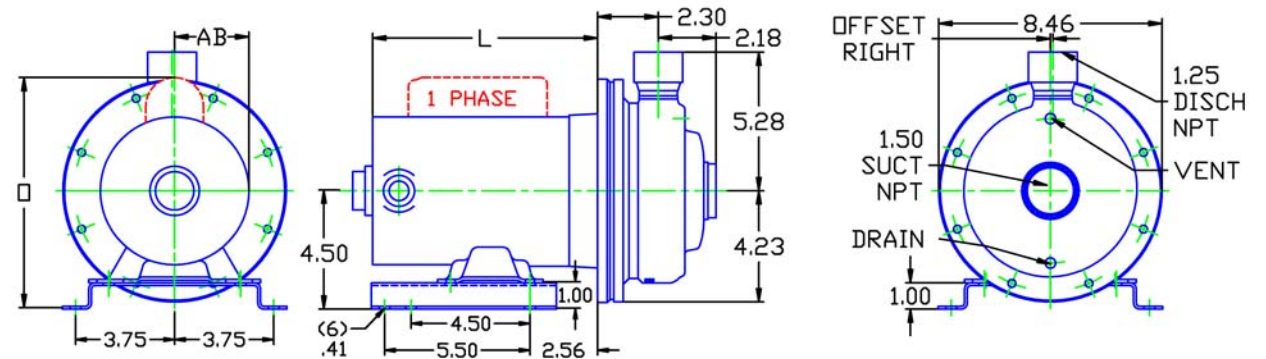

ALL DIMENSIONS IN INCHES.

DRAWING REPRESENTS APPROXIMATE PUMP DIMENSIONS. AUTOCAD DRAWING TO SCALE AVAILABLE FROM FACTORY.

PUMP TO BE
INSTALLED ONLY IN
THE HORIZONTAL
POSITION AS
SHOWN.

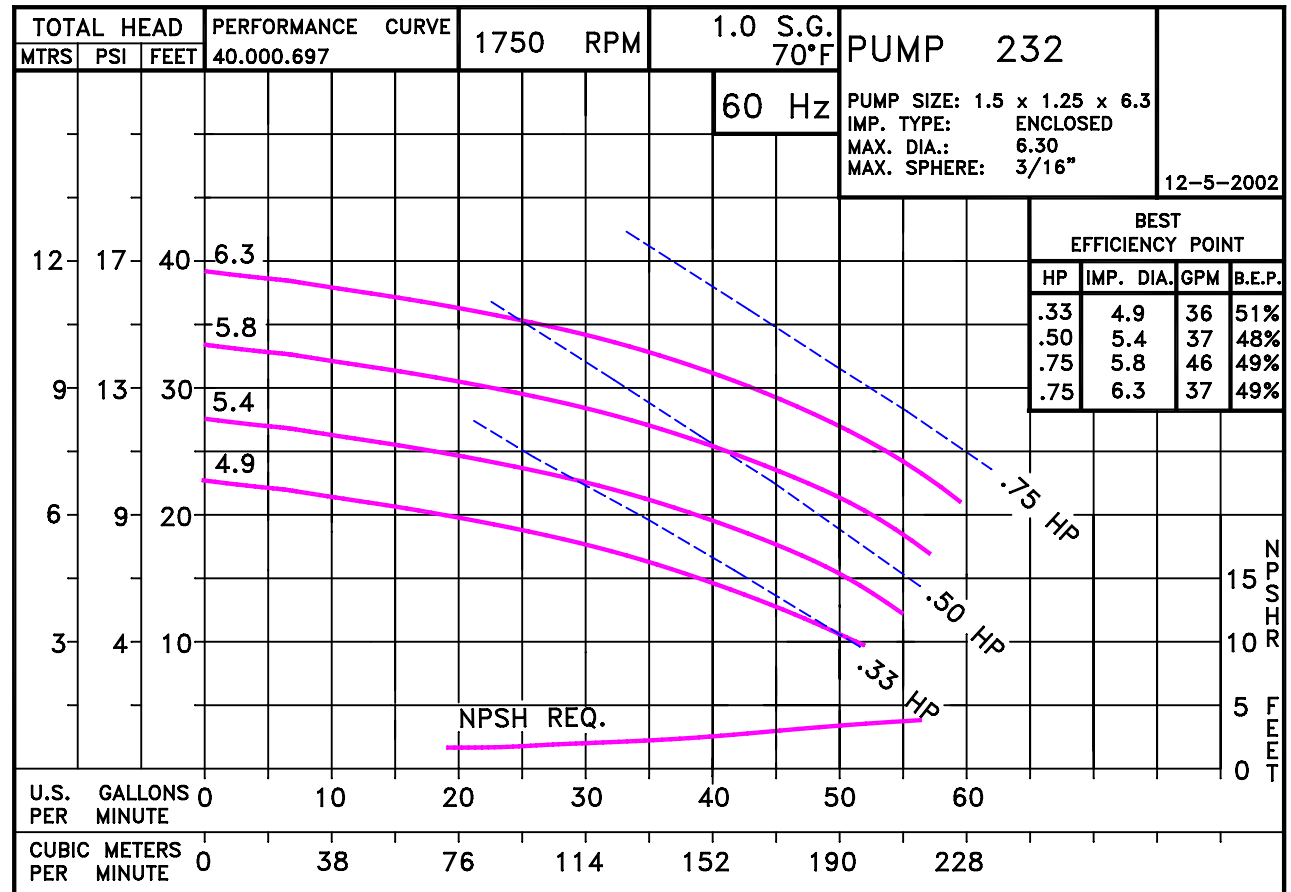

2325DP

D232J561750
2321750

232 J56

23231750J56
81.001.871 K12

Pump 232 • 304SS • J56 Frame • 1750 RPM

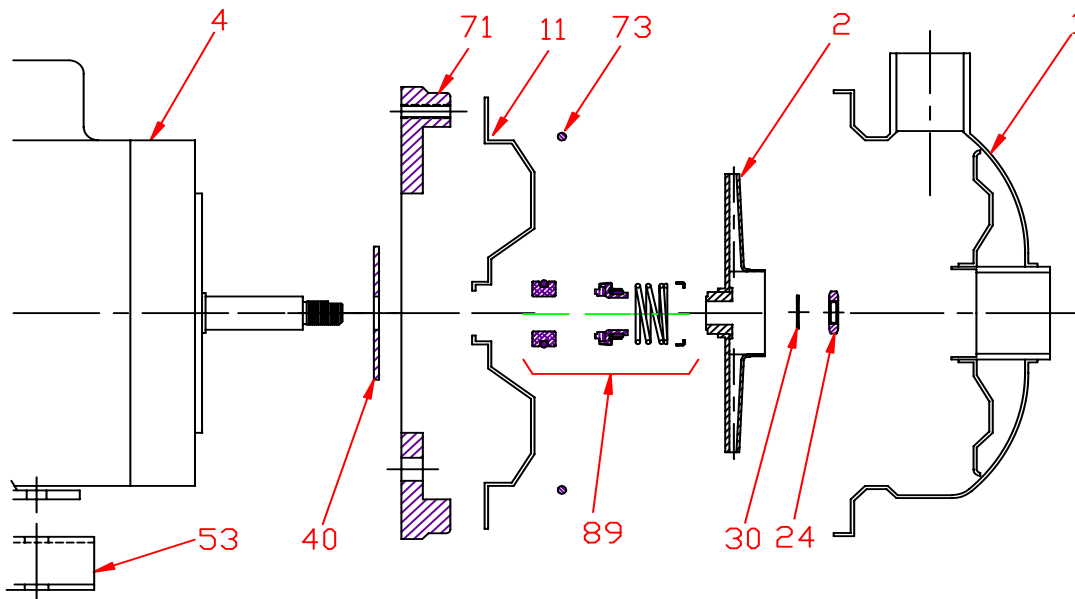

KEY NO.	PART NAME	PUMP 232	
1	CASE, 304SS, 1.5 x 1.25, NPT	137.001.314	
2	IMPELLER, STAINLESS, ENCLOSED, 7/16" THREADED:		
	4.90" DIA	137.001.318	
	5.40" DIA	137.001.317	
	5.80" DIA	137.001.316	
	6.30" DIA	137.001.315	
4	MOTOR:		
	J56/56, 3.5" RIGID BASE	See Chart	
11	COVER, STAINLESS	137.001.059	
24*+	NUT, 304SS	137.001.349	
30*+	D WASHER, 316SS	104.000.168	
40*	FLINGER, NEOPRENE	104.000.171	
53	BASE, STEEL	137.001.130	
71	DISC, IRON	137.001.046	
73*	GASKET, CASE, BUNA	137.001.121	
89*	5/8" SEALS WITH RETAINER:		
	TYPE 21, BN-CARB/SIL	137.002.401	
	TYPE 21, VN-CARB/SIL	137.002.390	
	TYPE 21, VN-SIL/SIL	137.002.406	
	TYPE 21, EPDM-CARB/SIL	137.002.258	
--	REPAIR KITS:	3 PHASE:	† 1 PHASE:
	BN-CARB/SIL SEAL	118.000.581	118.000.581.1
	VN-CARB/SIL SEAL	118.000.581E	118.000.581E.1
	VN-SIL/SIL SEAL	118.000.581F	118.000.581F.1
	EPDM-CARB/SIL SEAL	118.000.581C	118.000.581C.1

* DENOTES COMPONENTS INCLUDED IN REPAIR KIT.

+ NOT REQUIRED ON 1 PHASE MOTORS.

E231J56-B

K12

P2321750J56

Pump 232 • 304SS • J56 Frame • 1750 RPM

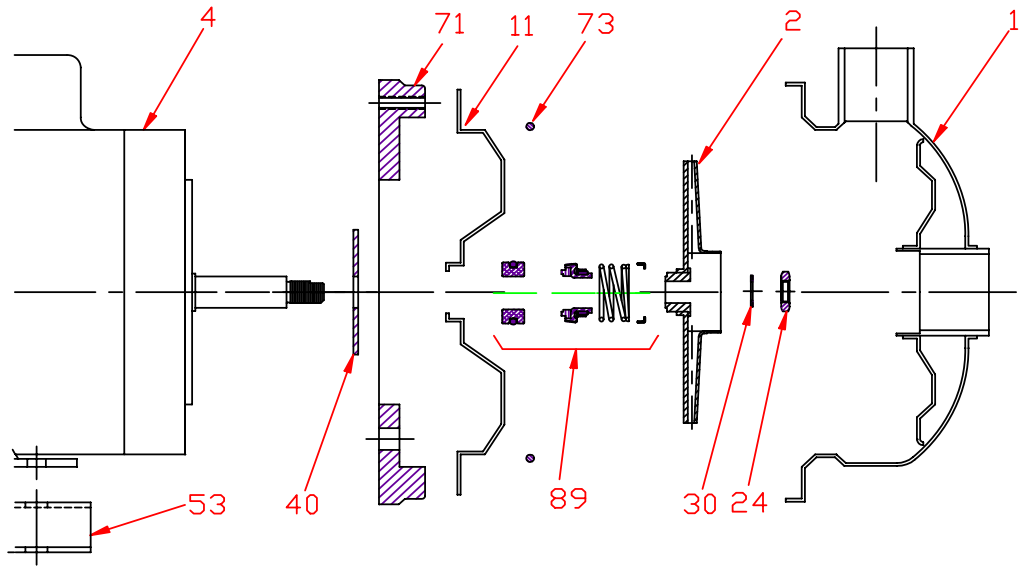

CONSTRUCTION OPTIONS		
KEY	PART NAME	STANDARD FITTED
1	Case	304SS
2	Impeller	304SS
11	Cover	304SS
24	Nut	304SS
30	D-Washer	316SS
40	Flinger	Neoprene
53	Base	Steel
71	Motor Disc	Cast Iron
73	Gasket, Case	Buna
89	Seal Assembly	BN-CARB/SIL
89A	Seal Retainer	304SS

E231J56-B

K12

C2321750J56